



Application System



OPERATION MANUAL

FOR SYSTEMS
USING ISOBUS
INTEGRATION

Copyright © 2017 Micro-Trak Systems Inc.



3RIVE 3D™

OPERATION MANUAL

FOR SYSTEMS USING ISOBUS INTEGRATION

The 3RIVE 3D Dual Plus ISOmod is the ISOBUS ready control system for the 3RIVE 3D application system. It is designed to connect to systems using ISOBUS, a standardized protocol for electronic communication between implements, tractors and computers (ISO 11783).

The 3RIVE 3D Dual Plus ISOmod is a dual channel rate controller that is pre-configured and optimized for the 3RIVE 3D system. The installation of the 3RIVE 3D system will vary depending on your equipment. Please take time to familiarize yourself with this manual and the actual components before beginning installation. Following the procedures described in this manual will help ensure proper performance and avoid problems or questions once you are in the field.

The 3RIVE 3D Dual Plus ISOmod can be configured for English, Metric, or Turf units. Please read the manual carefully and follow the instructions that apply to your usage.

If you do encounter a problem that cannot be corrected by reviewing this manual, consult your dealer or distributor, or contact a Micro-Trak® technician for assistance.

Capture® 3RIVE 3D™ insecticide is a restricted use pesticide. Always read and follow label directions.

FMC, 3RIVE 3D™, and Capture® are trademarks of FMC Corporation or an affiliate. They are used under license to Micro-Trak Systems Inc.

U.S. or Canada: Toll-free (800) 328-9613 or (507) 257-3600

Fax: 507-257-3001

www.micro-trak.com

Inquiries: trakmail@micro-trak.com



MICRO-TRAK®
SYSTEMS, INC.

P.O. Box 99
111 East LeRay Avenue
Eagle Lake, MN 56024-0099

© 2017 • Micro-Trak® Systems, Inc.

Micro-Trak® Warranty

Micro-Trak® (herein "Seller") warrants to the original purchaser (herein "Buyer") that, if any product or part of the product (herein "part") proves to be defective in material or workmanship, upon inspection and examination by Seller, within one (1) year from the original date-of-purchase, and is returned to Seller with dated proof-of-purchase, transportation prepaid, within thirty (30) days after such defect is discovered, Seller will, at their option and sole discretion, either repair or replace said part, except that the warranty for expendable parts, including but not limited to, light bulbs and batteries shall be thirty (30) days from the original date-of-purchase. Said warranty is valid only when the part has been installed, operated and maintained in strict accordance with the procedures outlined in the manual. Any damage or failure to said part resulting from abuse, misuse, neglect, accidental or improper installation or maintenance, unauthorized modification, use with other products or attributable to acts of God, as determined solely by the Seller, will invalidate the warranty. Said part will not be considered defective if it substantially fulfills the performance specification. Buyer shall be responsible for all maintenance services, if any, all in strict accordance with the procedures outlined in the manual. The warranty does not include labor, installation, replacement parts or repairs, delivery of replacement parts or repairs or time and travel. Said warranty is nontransferable.

THE FOREGOING WARRANTY IS EXCLUSIVE AND IN LIEU OF ALL OTHER WARRANTIES OF MERCHANTABILITY, FITNESS FOR PURPOSE AND OF ANY OTHER TYPE, WHETHER EXPRESSED OR IMPLIED. The Seller's liability, whether in contract, in tort, under any warranty, in negligence or otherwise, shall not exceed the return of the amount of the purchase price paid by the Buyer, and under no circumstance shall the Seller be liable for special, indirect or consequential damages. Seller neither assumes nor authorizes anyone to assume for it any other obligation or liability in connection with said part. No action, regardless of form, arising out of the transactions under this agreement may be brought by the Buyer more than one (1) year after the cause of action has occurred.

Seller agrees to extend the term of the foregoing warranty period should the Buyer return completed warranty registration information, with dated proof-of-purchase, to the Seller within one (1) year from the original date-of-purchase. All conditions and limitations of said foregoing warranty, except the term of said foregoing warranty, shall apply. Said term shall be extended to a total of three (3) years from the original date-of purchase on display consoles and network communication modules, as defined by Seller, and said term shall be extended to a total of two (2) years from the original date-of-purchase on all other parts, except that the warranty for expendable parts, including but not limited to, light bulbs and batteries shall be thirty (30) days from the original date-of-purchase, and except that the warranty for parts manufactured by someone other than the Seller, including but not limited to, shutoff and control valves, DGPS receivers, memory cards and drives, mapping software, flowmeters and pressure sensors shall be one (1) year from the original date-of-purchase.

Units under warranty should be sent prepaid, with dated proof-of-purchase, within 30 days of discovering defect, to the address below:

MAIL and UPS:
Micro-Trak® Systems, Inc.
ATTN: Service Department
P.O. Box 99
111 East LeRay Avenue
Eagle Lake, MN 56024-0099

Extended Warranty Option

It's simple! Just complete the registration for this product **ONLINE** at www.micro-trak.com and we'll extend your warranty for up to three years*, at no additional charge.

Registration information is for internal use only.

* Some limitations apply. See warranty statement for details.

At Micro-Trak® Systems, we believe a product that delivers quality and performance at a low cost is what is needed to help today's operator and the operator of the future compete in the world market.

It is our goal to provide operators with a line of electronic equipment that will help build and maintain an efficient and profitable operation that can be passed on to future generations.

We thank you for your purchase and hope that we can be of service to you in the future.

Micro-Trak® Systems, Inc.

Table of Contents

Micro-Trak [®] Warranty	3
Table of Contents	4
About This Manual	5
Important Considerations	5
System Overview	6
Operation	11
Control Summary	12
On Screen Display	12
Navigation	12
Controls	13
Alarms	13
Home	14
Totals Screen	16
Configuration Tab A	17
Configuration Tab B	18
Configuration Tab C	19
Charge	20
Pressure Release	21
Rinse	21
Channel Setup - Operation	22
Channel Setup - Implement	23
Channel Setup - Control	24
Channel Setup - System	25
Channel Setup - Alarms	26
Channel Setup - Outputs	27
Diagnostic 1	28
Diagnostic 2	29
Periodic Maintenance	30
End of Season Storage/ Winterization	34
Troubleshooting	35
SafeGuard™ Blockage Monitor	38
Appendix A – Default Settings	40
Appendix B – Wiring Diagrams	43
Appendix C - Channel Setup - Set PWM Limits	46
Appendix D - Channel Setup - Fine Tune Meter (Ch. 2 - chemical)	47
Appendix E – Fine Tuning Speed/Distance Calibration	48
Appendix D – Replacement Parts	49

About This Manual

This manual is tailored to the 3RIVE 3D™ application system. The full standard version of the SafeGuard blockage system manual is available online at www.micro-trak.com/resources/manuals.

Important Considerations

Water Quality

- Only CLEAN water should be used in water tank! No product mixing occurs in the tank.



Adding other chemicals to the clean water tank that are not approved by FMC may result in poor foam quality and degraded system operation.

The system warranty does not cover performance issues or equipment plugging/damage caused by adding chemicals to the clean water tank!

- Water should have a pH between 5.4-8.5 for best quality foam
- Hard water may produce poor quality foam.
- Rust – water should be free from rust particles. Extreme rust conditions may require additional filter maintenance or customer to find alternate water source.

Applying Product In-Furrow



When testing system with active product follow all chemical handling rules and safety procedures!

- Expanded formulation can be affected by several factors, including water quality (pH, hardness, etc.), application rate of chemical and water, air pressure, air orifice disk size, and ¼ inch tubing length.
- Discharged product should come out steadily from all rows. Product will break and tear when being tested with planter raised up and not moving.

Freeze warning



The 3RIVE 3D™ Application System uses water (which freezes at 32 degrees F) as a carrier component. The Capture 3RIVE 3D™ component is safe to temperature of 27 degrees F. To avoid damage caused from freezing, the system should be parked indoors or the Cold Evening procedure should be implemented, if night time temps are expected to be below freezing.

System Overview

The 3RIVE 3D™ application system is designed exclusively for use with 3RIVE 3D™ formulations on planters. The 3RIVE 3D™ Application System uses low water volumes to deliver crop protection products to the furrow. The system expands mixtures up to 50 times creating a three-dimensional continuous Zone of Protection delivered directly into the furrow. The Dual Plus™ controller controls both water and chemical to accurately apply 3RIVE 3D™ formulations at the desired application rates. The water and formulation is mixed at the correct ratio and then flows to the section control manifold. The section manifold contains shutoff valves to control both liquid and air for each section. The mixed liquid then travels to the 3RIVE 3D™ manifolds where the product/water mixture and air are combined and the expanded formulation (foam) is created. The manifold has blockage sensors for each row. The foam flows through the blockage sensor to a row unit and out through a delivery nozzle located in furrow.

Tank Assembly

The tank assembly contains a 130 gallon water tank, 30 gallon product tank, Pump-Pak™, air compressor, control valves and all plumbing necessary for control and mixing of the water and chemical. It is mounted on the planter frame. The water and product remain separate until combined at the solution pump inlet.



Tank Assembly

Power Switch Module

This module controls the supply of electricity to the ISOmod preventing battery drain when not in use. When vehicle voltage is present at the accessory power line at the Speed Connection, a relay turns on main power to the ISOmod - and vice versa. A green LED on the potted enclosure will light when power is turned on to the ISOmod.

Note: if the Speed input on the ISOmod harness is in use, install a "Y" cable - available from Micro-Trak, PN 18048.

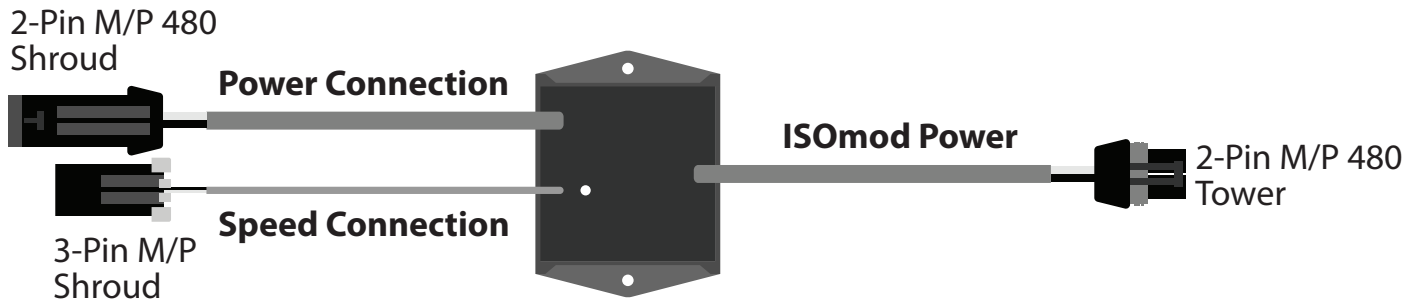

Pump-Pak™ Assembly

The Pump-Pak™ is mounted on the tank assembly. It contains both water and chemical pumps, control valves and other devices necessary to precisely apply the product. It consists of:

- Chemical pump
- Solution pump
- Flowmeter
- Strainer
- Three-way valves for calibration/draining of tanks
- Electric motor drivers
- Relay module
- Pressure sensor
- Air compressor

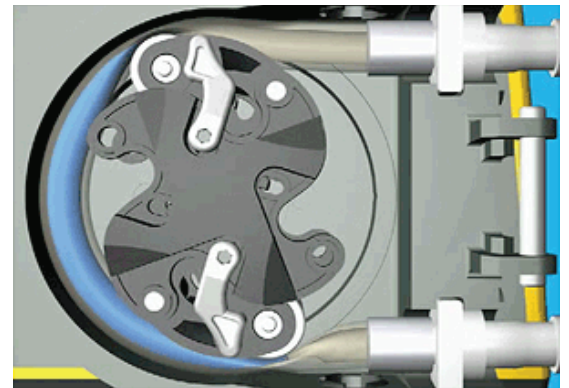

Chemical Pump

Chemical Pump

The chemical pump is a precision peristaltic pump. A peristaltic pump is a type of positive displacement pump. The fluid is contained within a flexible tube fitted inside a circular pump casing. A rotor compresses the flexible tube. As the rotor turns, the part of the tube under compression is pinched closed thus forcing the fluid to be pumped to move through the tube. Additionally, as the tube opens to its natural state after the passing of the cam fluid flow is induced to the pump.

The chemical first passes from the tank through a shutoff valve, mesh filter, and a three-way valve to the pump tube inlet. The controller monitors the rpm of the pump to determine the ounces per minute of chemical flow. The output of the pump goes to the inlet of the solution pump. Here it is mixed with water.

Water flows from the tank through a shutoff valve, filter and a three-way valve to the solution pump inlet. Here it is mixed with the chemical.

Channel 2 controls the chemical pump to the rate of chemical. Channel 1 controls the solution pump to achieve the desired chemical + water total volume. This combined channel 1 volume is typically the desired chemical rate x 5, or 40 ounces per acre, whichever is greater.

The water/chemical solution is then pumped through a precision flowmeter out to the system manifolds. Pressure is monitored by the controller via a pressure sensor mounted on the output side of the solution pump.

The pump is controlled via a 12 VDC electric motor driver module.

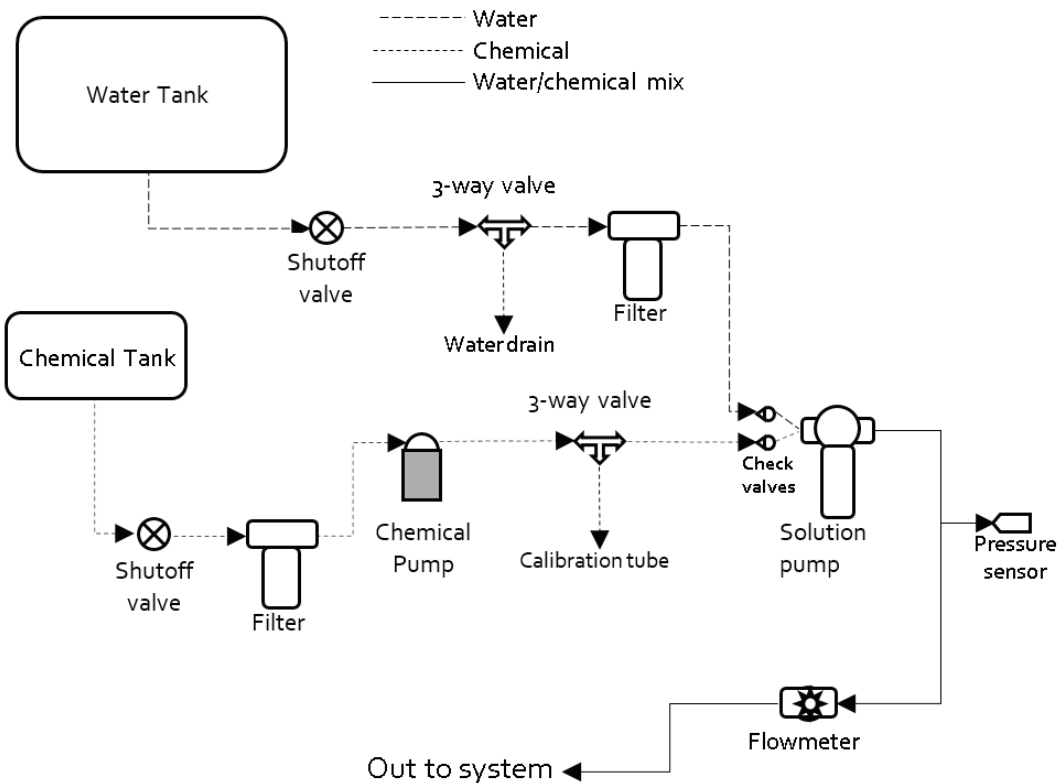

Pump-Pak diagram™

Solution Pump

The solution pump is controlled via a 12 VDC electric motor driver module. Water and chemical are supplied to the input side of the pump. The pump is controlled to provide the combined chemical/water rate as set in channel 1. This rate is typically the desired chemical rate in ounces per acre x 5, or 40 ounces whichever is greater. The water and chemical is mixed in the pump and the solution is then pumped out to the manifold assemblies.

Flowmeter

The flowmeter is a low-volume precision flowmeter. It measures the combined water/chemical solution after it exits the solution pump. From there the solution passes to the manifolds.

Strainers

The system uses two #50 mesh strainers to strain the chemical and water before entering the Pump-Pak™. The chemical strainer has a bottom drain to minimize spilling chemical when removing strainer bowl for cleaning.

Electric Motor Drivers

The pumps are powered by 10 amp electric motor drivers (EMD). There is one for each pump. The EMD has three connections; battery in, power out to motor, and control. The controller adjusts the RPM of each pump through these EMD modules. It has status and control input indicators. See troubleshooting section for more information

Relay Module

The air compressor is turned on via a relay module. It has three connections; battery in, power out to compressor, and control. The controller turns the compressor on whenever a section is turned on. If all sections are off, the compressor is turned off. If a second compressor is used, another module will control it turning it on as needed. The relay module has a status indicator that lights when the relay module is on.

Pressure Sensor

The pressure sensor located in the Pump-Pak™ monitors the pressure of the solution as it leaves the Pump-Pak™. This is displayed on the pressure position on the rotary dial with channel 1 selected.

Air Compressor

The air compressor turned on whenever the system has at least one section turned on. If all sections are turned off, or the ground speed goes to 0 the compressor is shut off. The compressor is full on or off; there is no variable control of the output pressure. This is adjusted through the air regulator located on the planter. Air pressure is displayed on the pressure position on the rotary dial with channel 2 selected. The air compressor has a replaceable air filter element.

3RIVE 3D™ Manifold Assembly

There is one 3RIVE 3D™ manifold assembly per section. The 3RIVE 3D™ manifold assembly generates the foam and distributes it across the individual rows.

It consists of:

- Steel mounting bracket
- SafeGuard™ blockage sensors
- Foam mixing tower
- Air shutoff valve
- Solution shutoff valve

Air enters the mixing tee at the bottom, and the water/product mix enters the side of the mixing tee. Foam is generated inside the tower and is distributed through the SafeGuard™ blockage sensors to the individual rows. The manifold assembly consists of the bottom mixing tee and upper foam tower. The air is introduced at the bottom of the mixing tee. The chemical solution enters the mixing tee at the side and is sprayed into the airstream. It is easier to remove the mixing tee from the foam tower when cleaning the orifices.

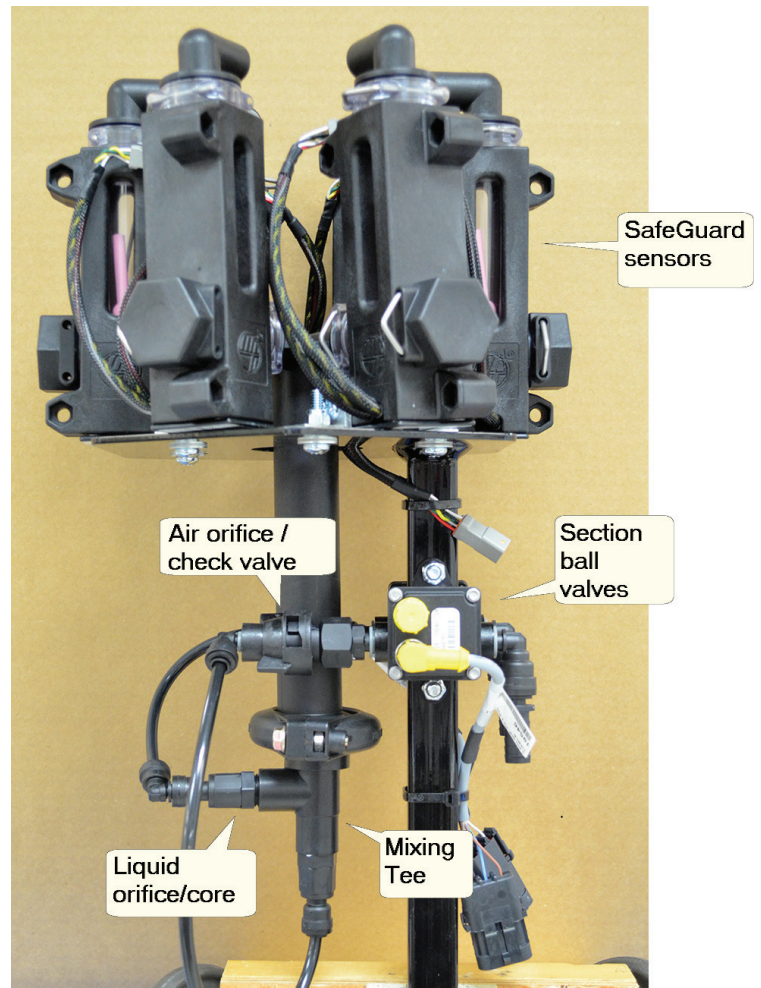

Row Delivery

Foam is delivered to the row via ¼" tubing travelling from the SafeGuard™ blockage sensor. A stainless steel tube is used at the row unit to ensure a uniform bead of foam is applied to each furrow. There is a valve on each row to provide immediate shutoff of foam delivery.



Row unit seed firmers



Foam delivery

Operation

Charge and Rinse Procedures

Preparing for Operation – Charging the System

This procedure will get air out of the system, and fill all components with solution or foam making it ready for use. This charge routine will run until one of the following occurs:

- Charge cycle duration timer expires
- A NO FLOW error persists for greater than 15 seconds after initial flow is established

End of Day – Rinsing the System



It is recommended that the mixed solution of 3RIVE 3D™ Product and water be rinsed from the system at the end of the day. This rinsing will help prevent plugging of orifices, strainers, and lines. This rinse routine will run until one of the following occurs:

- Rinse cycle duration timer expires
- A NO FLOW error is detected indicating water tank is empty

NOTE: In rinse mode, with the section switches ON and the system in HOLD, the pumps are turned off but the sections remain ON which allows pressure to bleed off the system. When the system is placed in RUN the rinse mode continues with channel 1 pumping water through the system.

See page 20-21 for complete Charge and Rinse Procedures

Determining channel 1 and 2 target rates

3RIVE 3D™ is applied in ounces per acre. The product is injected into water which is necessary to facilitate the generation of foam.

- Channel 1 controls the ounces of water per acre being used as the carrier. Channel 1 supplements the chemical to bring the total combined flow rate to the value calculated below..
- Channel 2 controls the ounces of chemical being applied per acre.
- Minimum combined volume of chemical and water is 40 ounces per acre.
- It is recommended that the ratio of WATER to 3RIVE 3D™ product be maintained at 4 to 1 whenever possible.

Determining Channel 1 Rate: 3RIVE 3D™ Rate x 5 or 40 ounces per acre **whichever is greater.**

Examples

1. # 1: If 3RIVE 3D™ Product rate is 4-8 ounces per acre Channel 1 Rate (total volume) should be 40 ounces per acre.
2. # 2: If 3RIVE 3D™ Product rate is 10 ounces per acre Channel 1 Rate should be 50 ounces per acre.
3. # 3: If 3RIVE 3D™ Product rate is 12 ounces per acre Channel 1 Rate should be 60 ounces per acre.
4. # 4: If 3RIVE 3D™ Product rate is 16 ounces per acre Channel 1 Rate should be 80 ounces per acre.

Channel 1 Target Rate

Channel 1 measures the combined water/chemical solution prior to it being turned into foam. It injects water into the chemical stream to bring the total volume up to the desired level.

3RIVE 3D™ target (oz. per acre) _____ X 5 = _____ Channel 1 Target Rate (40 minimum setting)

Channel 2 Target Rate

Channel Target Rate = _____ 3RIVE 3D™ ounces per acre

These rates can be adjusted to improve foam protection band delivery. Increasing the water rate can help make up for poor foam quality due to hard water, but **NEVER** exceed water to 3RIVE 3D™ ratio of 10 to 1.

Example: If satisfactory foam delivery is not achievable with CH2 rate of 4 ounces per acre and a CH1 Rate of 44 ounces per acre higher quality water or an increase in 3RIVE 3D™ product will be needed.

Control Summary

The following is an overview of the 3RIVE 3D™Dual Plus™ ISOmod control system. The 3RIVE 3D™ controller is a multi-section, dual channel controller. The controller is pre-programmed with default settings tailored for 3RIVE 3D™ application.

For 3RIVE 3D™ application the controller is used in Injection mode. Channel 2 (product) is injected into channel 1 (water). The water is needed to create the expanded foam product formulation. Function selection and display are on the left side of the console.

On Screen Display

The 3RIVE 3D Dual Plus ISOmod is designed to integrate into serial networks that use ISOBUS standards - ISO 11783. The appearance of the on-screen display will vary depending on the brand of Virtual Terminal that is used.

The system is also designed to run along side, and in the background, with other programs on the VT. When an alarm situation happens, the 3RIVE 3D Dual Plus ISOmod screen will pop-up to the front to allow the user to assess the situation.

Navigation

This diagram shows navigation paths through the control screens via keys displayed on the Virtual Terminal. Controlling the 3RIVE 3D system is only possible from the Home or Totals screens (the controls on the Totals screen is limited to switching from Automatic to Manual, engaging Run/Hold switch, and controlling audible alarm volume).

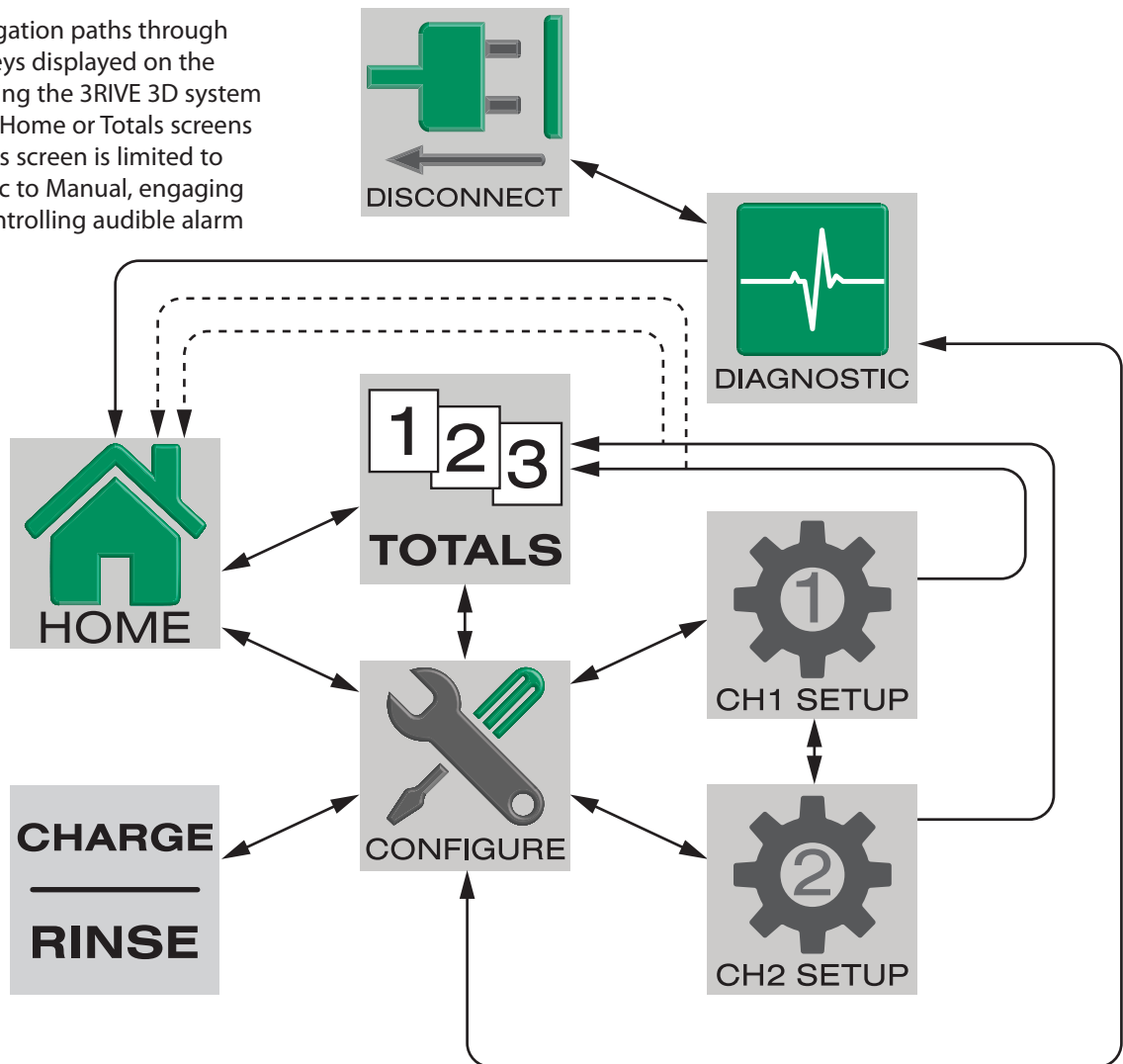

Controls

VT Softkeys

Example:



Virtual terminal controls are displayed along the right side or bottom of the screen, in accordance with ISO standards. Depending on their function, VT softkeys navigate from screen to screen, or activate functions - Run/Hold etc.

On-screen keys

Example:



On-screen keys are controls that activate functions, directly affect numerical values, or navigate to specific setup routines.

Drop down boxes

Example:



Drop down boxes are rectangular and allow the user to choose options from a provided list.

Input Boxes

Example:



Input boxes are rectangular and allow the user to input alphanumeric values from a pop-up keypad on screen.

Check Boxes

Example:



Square check boxes allow the user to activate a function. The function will remain in that state until the box is pressed again.

Alarms

If a parameter on the 3RIVE 3D system significantly exceeds, or falls short of established limits, an Alert Message similar to the one shown will appear in front. The Alert Message explains the alarm situation, gives critical information, and lists possible fixes or next steps. To clear alert message, press confirm. It is possible to return to alert message later by pressing on the flashing alarm icon.

Alert Pop-up Screen example:

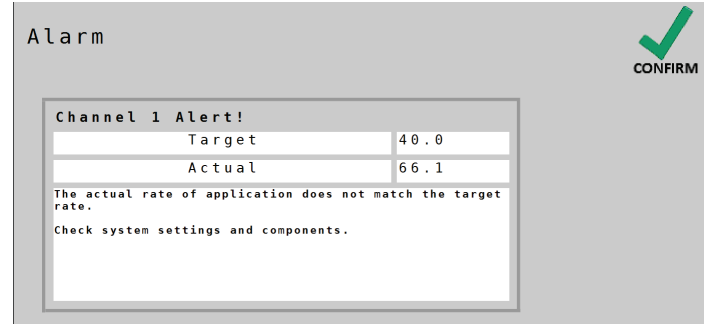

Alarm Icon:



Home

This is the main operating screen for the 3RIVE 3D system.

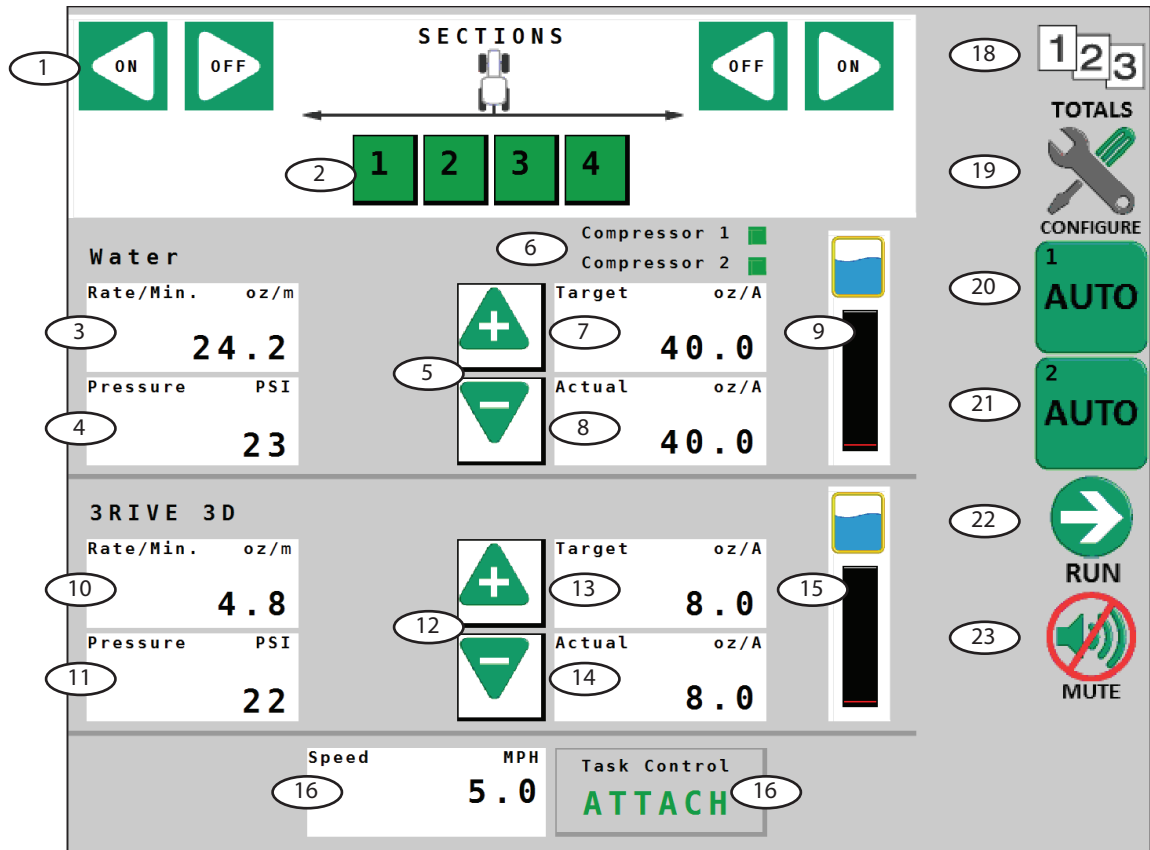

1 Section On/Off switches

These are the controls for sections activation. The sections can be toggled on/off from either direction using the on/off buttons.

2 Section Indicators

Sections can also be toggled by pressing directly on the numbered rectangular section indicators below the tractor image. The number of sections (and corresponding widths) is specified in **Ch. 1 Setup/Implement**.

3 Ch.1 Information Display

This display shows Channel 1 Rate/Minute as default. The units shown at upper right corner reflect the default unit of measure. This window can also be reconfigured by selecting the window and choosing from Pressure, Volume (data from Ch. 1 Totals Tab 1 volume), or Ch. 1 PWM Duty Cycle.

4 Ch.1 Information Display

This display shows Pressure as default. The units shown at upper right corner reflect the default unit of measure. This window can also be reconfigured by selecting the window and choosing from Rate/min., Volume (data from Ch. 1 Totals Tab 1 volume), or Ch. 1 PWM Duty Cycle.

5 Ch.1 Increase/Decrease

These on-screen keys increase (+) or decrease (-) the overall Rate of application. If channel is set to Automatic, the Increase/Decrease buttons will affect the Target Rate in preset increments. The increment of change per key press is defined in **Ch.1 Setup/Operation tab** (default=1). When channel is set to Manual, the Increase/Decrease buttons change the Actual rate of application based on the length of time the button is held down.

6 Compressor Indicators

These indicators show when system air compressors are active. The activity is controlled by the Multifunction output(s) of the system. If 2 air compressors are needed to achieve proper foam creation, the 2nd compressor will activate above a given flow rate. The default threshold value is 15 oz./min. This value can be accessed in **Ch.1 Setup/Outputs**.

7 Ch.1 Target Rate

This display shows the overall Target Rate of the system. That rate is the **combined** rate of the solution of water and chemical. The target rate can be incrementally adjusted using Increase/Decrease on-screen keys. The setting for Target Rate is located in **Ch.1 Setup/Operation**.

8 Ch. 1 Actual Applied Rate

This display shows the actual applied Rate of the system. If the Actual Applied Rate is different than the Target Rate, an alarm will pop-up to notify the operator. The Rate Alarm Threshold setting is located in **Ch.1 Setup/Alarms** tab.

9 Ch. 1 Tank Level

This display shows the amount of liquid remaining in the tank. For Ch.1, this reading is the amount of water in the 130 gal. tank. The red line shows the approximate value of the Tank Alarm. (To enter Tank information at refill, see Totals screen.)

10 Ch.2 Information Display

This display shows Channel 2 Rate/Minute as default. The units shown at upper right corner reflect the default unit of measure. This window can also be reconfigured by selecting the window and choosing from Pressure, Volume (data from Ch. 2 Totals Tab 1 volume), or Ch. 2 PWM Duty Cycle.

Home - cont.

11 Ch.2 Information Display

This display shows Pressure as default. The units shown at upper right corner reflect the default unit of measure. This window can also be reconfigured by selecting the window and choosing from Rate/min., Volume (data from Ch. 2 Totals Tab 1 volume), or Ch. 2 PWM Duty Cycle.

12 Ch. 2 Increase/Decrease

These on-screen keys increase (+) or decrease (-) the overall Rate of application. If channel is set to Automatic, the Increase/Decrease buttons will affect the Target Rate in preset increments. The increment of change per key press is defined in **Ch.2 Setup/Operation tab** (default=1). When channel is set to Manual, the Increase/Decrease buttons change the Actual rate of application based on the length of time the button is held down.

13 Ch. 2 Target Rate

This display shows the overall Target Rate of the system. That rate is the **combined** rate of the solution of water and chemical. The target rate can be incrementally adjusted using Increase/Decrease on-screen keys. The setting for Target Rate is located in **Ch.2 Setup/Operation**.

14 Ch. 2 Actual Applied Rate

This display shows the actual applied Rate of the system. If the Actual Applied Rate is different than the Target Rate, an alarm will pop-up to notify the operator. The Rate Alarm Threshold setting is located in **Ch.2 Setup/Alarms** tab.

15 Ch. 2 Tank Level

This display shows the amount of liquid remaining in the tank. For Ch.2, this reading is the amount of water in the 130 gal. tank. The red line shows the approximate value of the Tank Alarm. (To enter Tank information at refill, see Totals screen.)

16 Task Controller Attach

This button will attach the 3RIVE 3D system to the Task Controller on the network. Task Controller parameters in Configuration-tab B, and Channel Setup-Implement tab **MUST** be measured and entered before attachment. Changing those parameters is **NOT** possible once the 3RIVE 3D system is attached.

17 Speed

This displays vehicle speed. The speed source for the system is defaulted to **Remote** to access speed information from the ISOBUS network. The label on the Speed window shows the source of the speed signal - Blended, GPS, Wheel, or Ground (radar).

The setting for speed source is located in Configuration/Tab A. To connect an alternate speed source directly to the 3RIVE 3D wiring harness, choose **Local** in Configuration Tab A - Speed Source.

18 Totals

This VT Softkey directly navigates to the Totals screen.

19 Configure

This VT Softkey directly navigates to the Configure screen.

20 Ch. 1 Auto/Manual

This VT Softkey selects Automatic or Manual control of application.

21 Ch. 2 Auto/Manual

This VT Softkey selects Automatic or Manual control of application.

22 Run/Hold

This VT Softkey controls Run/Hold (application on/off) for entire system.

23 Alarm Mute

This VT Softkey controls the audible alarm mute. When engaged, audible alarms are turned off.

Totals Screen

This is the Totals screen for the 3RIVE 3D system. It can also be used as an operating screen.

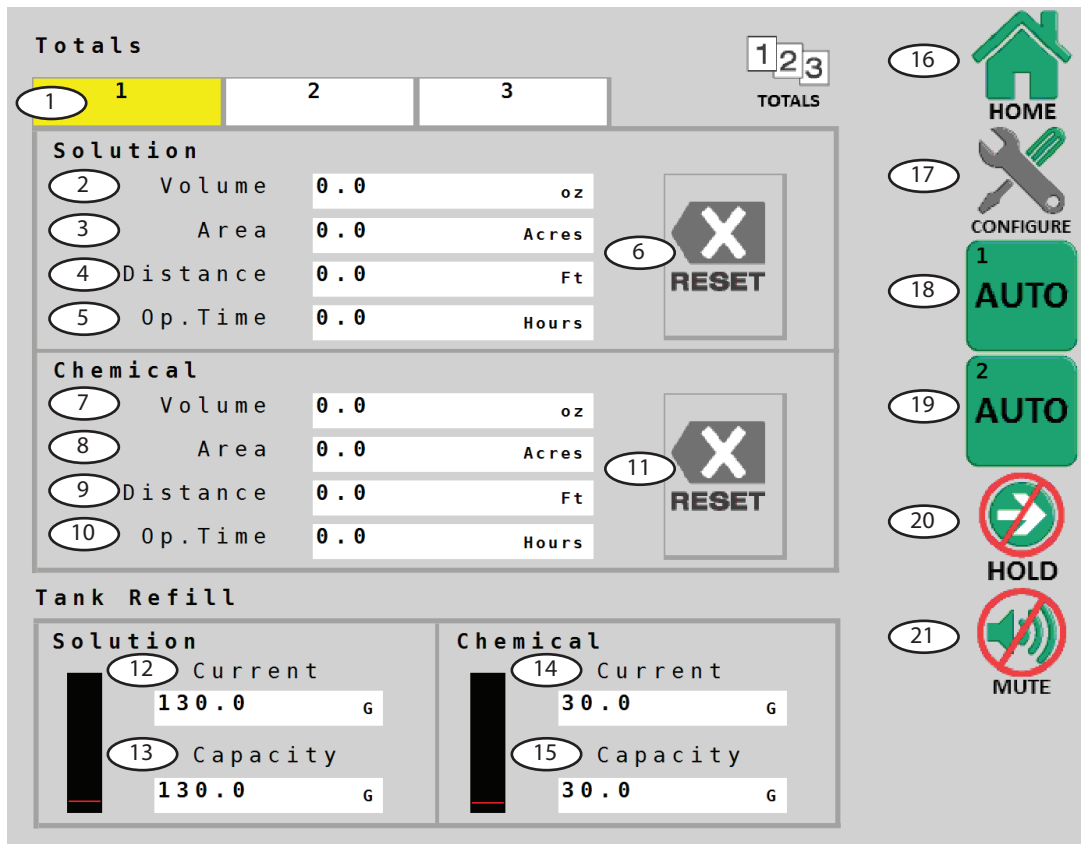

1 Totals Tabs

There are 3 independent sets of Totals counters separated into the 2 channels. The highlighted tab indicates which counter set is shown. Counters do not accumulate data when system is in HOLD or when sections are turned off.

2 Ch. 1 Volume Counter

Displays the total volume of product applied in ounces (ml). The current default unit of measure is shown at right side.

3 Ch. 1 Area Counter

Displays the running total of total area worked in acres (hectares). The current default unit of measure is shown at right side.

4 Ch. 1 Distance Counter

Displays cumulative distance traveled in feet or Meters.

5 Ch. 1 Operating Time

Displays the cumulative running time of the system.

6 Ch. 1 Totals Reset

Clears the counter of information (after the confirmation screen). Reset only applies to the Tab that is currently shown.

7 Ch. 2 Volume Counter

Displays the total volume of product applied in ounces (ml). The current default unit of measure is shown at right side.

8 Ch. 2 Area Counter

Displays the running total of total area worked in acres (hectares). The current default unit of measure is shown at right side.

9 Ch. 2 Distance Counter

Displays cumulative distance traveled in feet or Meters.

10 Ch. 2 Operating Time

Displays the cumulative running time of the system.

11 Ch. 2 Totals Reset

Clears the counter of information (after the confirmation screen). Reset only applies to the Tab that is currently shown.

12 Ch. 1 Tank Refill - Current

Enter current amount of water in tank. For full refill, enter 130 gal (492 liters).

13 Ch. 1 Tank Refill - Capacity

The capacity of Ch. 1 tank is 130 gal (492 liters).

14 Ch. 2 Tank Refill - Current

Enter current amount of water in tank. For full refill, enter 130 gal (492 liters).

15 Ch. 2 Tank Refill - Capacity

The capacity of Ch. 1 tank is 30 gal (492 liters).

16 Home

This VT Softkey directly navigates to the Totals screen.

17 Configure

This VT Softkey directly navigates to the Configure screen.

18 Ch. 1 Auto/Manual

This VT Softkey selects Automatic or Manual control.

19 Ch. 2 Auto/Manual

This VT Softkey selects Automatic or Manual control.

20 Run/Hold

This VT Softkey controls Run/Hold (application on/off).

21 Alarm Mute

This VT Softkey controls the audible alarm mute. When engaged, audible alarms are turned off.

Configuration Tab A

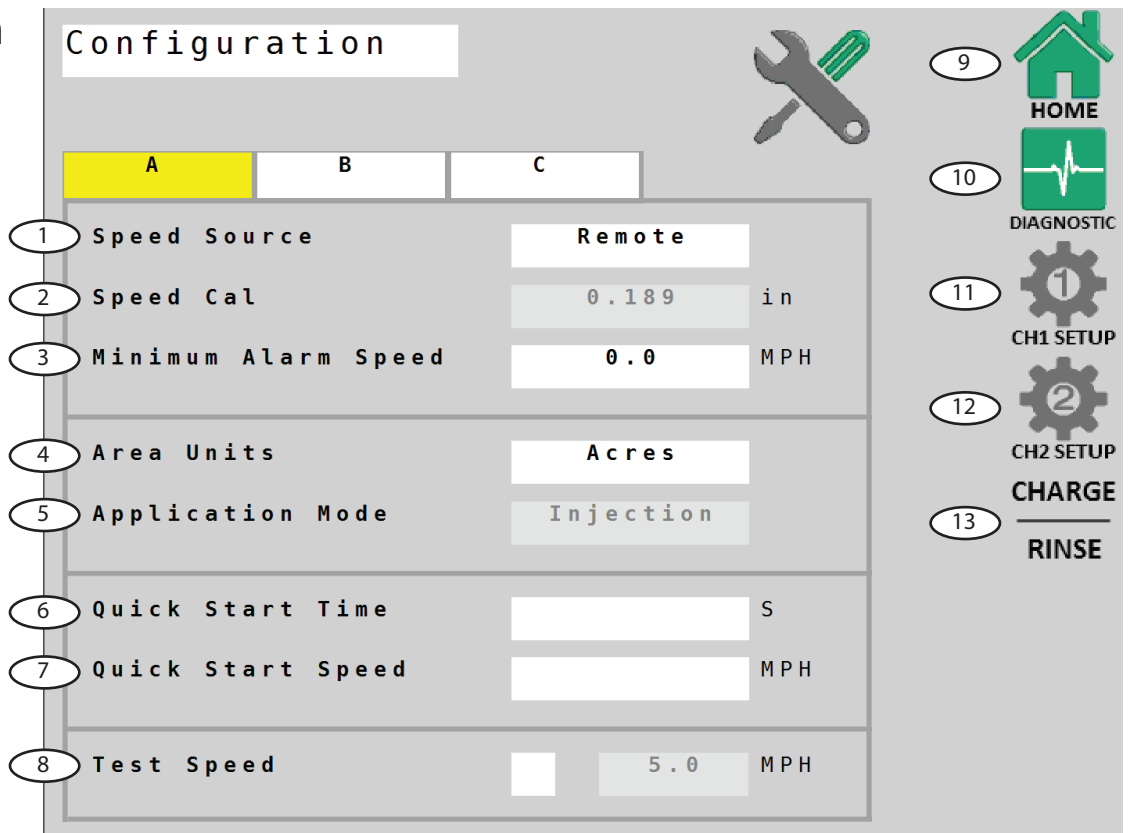

1 Speed Source

Select Speed Source for the system. Default is **Remote** - ISOBUS speed signal. Select **Local** to use a speed sensor connected directly to the 3RIVE 3D wiring harness.

2 Speed Cal

Speed calibration number for Local speed - automatically defaulted to .189 for Micro-Trak Astro II and 5 GPS speed sensors. (Data entry is disabled unless Local is chosen in Speed Source.)

3 Minimum Alarm Speed

Enables and adjusts a minimum speed threshold for the audible alarm - this prevents unneeded warnings while stopping and starting. This can be set to OFF (0) or from 0.1 to 99.9 mph (km/h). Affected alarms are Application Rate Error and Minimum Flow.

4 Area Units

Select preference for Area Units for calculations and display. Default unit is **Acres** - other choices are **1000 sq. ft.**, or **Sq. Yards**. Exercise caution when changing Area Units, the controller software will not automatically re-calculate rate of application etc.

5 Application Mode

The default setting for 3RIVE 3D application is **Injection Mode**. This setting is permanently selected and cannot be changed.

6 Quick Start Time

Enables Quick Start Time feature (0=off). This sends a timed simulated speed signal to the control system to cause an instant transition from Hold to Run. The duration range is from 0 (off) to 6 seconds.

7 Quick Start Speed

Assigns a Speed value in MPH (km/h) for Quick Start feature (see previous).

8 Test Speed

Check here to send a simulated speed signal to the control system for system checkout or diagnostics while implement is parked.

9 Home

VT Softkey - directly navigates to the Totals screen.

10 Diagnostic

VT Softkey - directly navigates to the Diagnostic screen.

11 Ch. 1 Setup

VT softkey - directly navigates to Ch. 1 Setup.

12 Ch. 2 Setup

VT softkey - directly navigates to Ch. 2 Setup.

13 Charge / Rinse

VT softkey - directly navigates to Charge / Rinse for pre-field and post-application maintenance routines.

Configuration Tab B

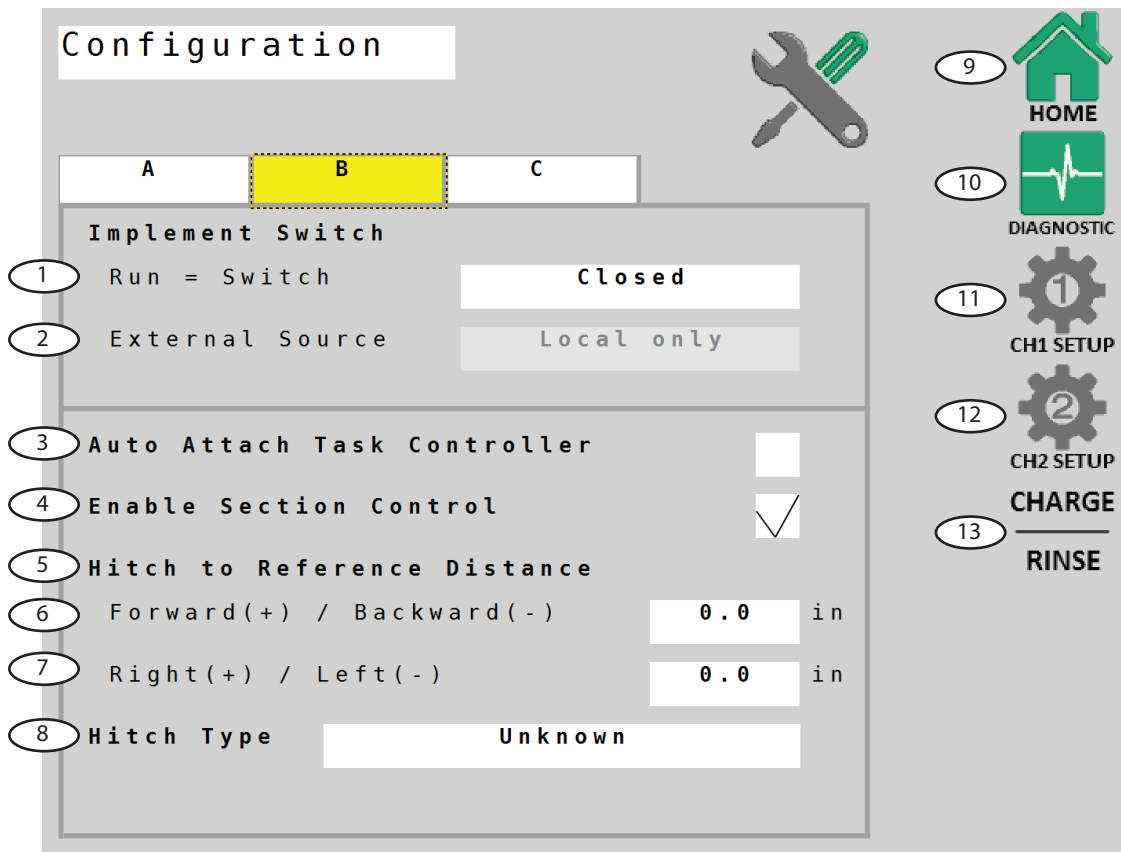

1 Implement Switch - Run=Switch

Selects polarity for remote Implement Switch connection - reverses circuit function. The default setting is closed, meaning that 3RIVE 3D system will be in Hold when the circuit is closed.

2 Implement Switch - External Source

The default setting for 3RIVE 3D application is **Local Only**. This setting is permanently selected and cannot be changed.

3 Auto Attach Task Controller

This check box tells the system to automatically connect to the available Task Controller. The Task Controller parameters in Configuration-tab B, and Channel Setup-Implement tab **MUST** be measured and entered before attachment. Changing those parameters is **NOT** possible once the 3RIVE 3D system is connected.

4 Enable Section Control

This allows the Task Controller to control section on/off. Default setting is ON.

5 Hitch to Reference Distance

These parameters establish a Reference Point for the Task Controller to measure from for accurate position calculations. Choose a reference point that is convenient, preferably the center of the axle (or toolbar). The remaining distance from this reference point to the first point of application will be entered in Channel 1 setup. See illustration.

6 Forward (+) / Backward (-)

Measure the forward or backward distance from the hitch to the Task Controller Reference Point.

7 Right (+) / Left (-)

Measure the right or left distance from the hitch to the Task Controller Reference Point. If the implement has no offset, leave value at 0.

Hitch to Reference Measurements

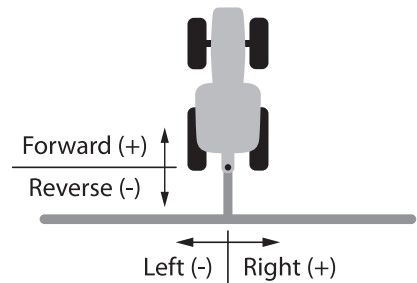

8 Hitch Type

Choose your hitch type. This choice allows the system to process in-field calculations more accurately.

9 Home

VT Softkey - directly navigates to the Home screen.

10 Diagnostic

VT Softkey - directly navigates to the Diagnostic screen.

11 Channel 1 Setup

VT softkey - directly navigates to Ch. 1 Setup.

12 Channel 2 Setup

VT softkey - directly navigates to Ch. 2 Setup.

13 Charge / Rinse

VT softkey - directly navigates to Charge / Rinse for pre-field and post-application maintenance routines. See page 20-21 for detailed explanation on Charge / Rinse routine.

Configuration Tab C

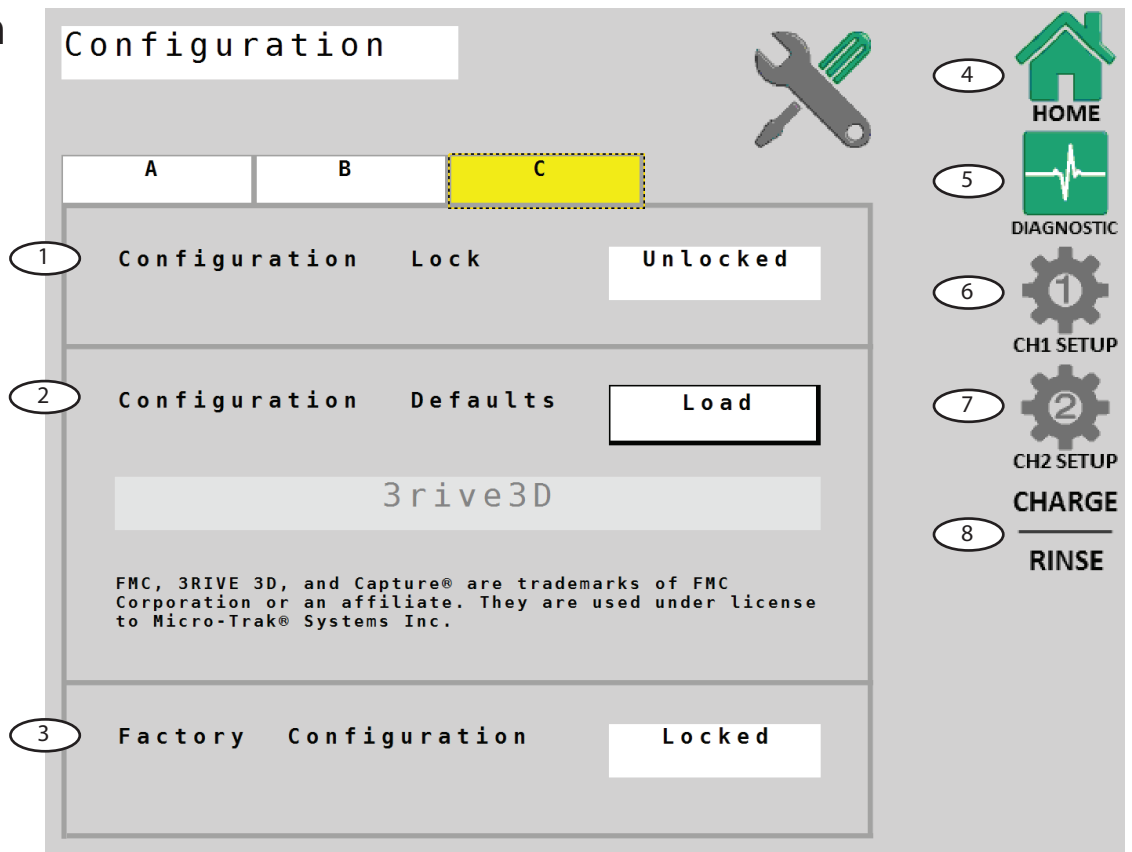

1 Configuration Lock

This feature locks both **Configuration Defaults** and **Factory Configuration** on this page. To lock these, press “Unlocked” and enter code 1320. To unlock, enter the same 1320 code.

2 Configuration Defaults

The feature will reset all parameter back to factory defaults, including erasing all Totals data.

3 Factory Configuration

This button unlocks access to system software configuration parameters. Access to this configuration is locked by default. Should access become necessary, an code will be provided by a qualified service technician.

4 Home

VT Softkey - directly navigates to the Home screen.

5 Diagnostic

VT Softkey - directly navigates to the Diagnostic screen.

6 Channel 1 Setup

VT softkey - directly navigates to Ch. 1 Setup.

7 Channel 2 Setup

VT softkey - directly navigates to Ch. 2 Setup.

8 Charge / Rinse

VT softkey - directly navigates to Charge / Rinse for pre-field and post-application maintenance routines. See page 20-21 for detailed explanation on Charge / Rinse

Charge

The charge routine automatically opens the section valves and activates the system in simulated ground speed mode of 6 mph (not adjustable). This charges the entire system from the pump through the row units with chemical/water solution to prepare the system for field use. The system will run the charge routine until cancelled by the operator, a NO FLOW alarm that lasts longer than 15 seconds, or the CHARGE TIME timer expires. The CHARGE TIME timer can be adjusted by pressing the number and entering a new value before entering the Charge routine.

Procedure:

1. Enter Charge/Rinse from Configurations screen by pressing the Charge/Rinse softkey.

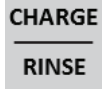

2. Enter the Charge routine by pressing the Charge softkey.



3. Begin the Charge routine by pressing the HOLD softkey.



The system will pump solution through the system. The charge routine should run until a consistent flow of foam is coming out of each row unit. Typically the middle sections produce continuous foam first, followed by the outside sections. When a section is making acceptable foam, turn that section off. This will reduce the overall amount of chemical discharged during the charge routine. When all sections are producing adequate foam, turn on all sections again and verify that the SafeGuard monitor is showing ALL GOOD. The charge routine is now complete.

4. Stop the Charge routine by pressing the HOLD softkey again.



5. Exit the Charge routine by pressing the HOME softkey.



Charge Screen

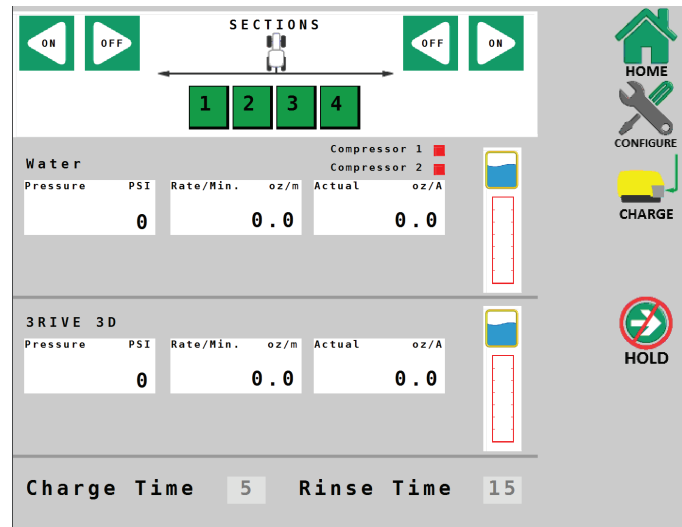

Pressure Release

To prevent injury or damage to equipment, release all pressure in solution and air lines during maintenance or troubleshooting.

Procedure:

1. Enter Charge/Rinse from Configurations screen by pressing the Charge/Rinse softkey.

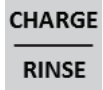

2. Release system pressure by pressing the Pressure Release softkey. "Pressure Release" label turns green to indicate valves have opened.



3. After pressure is released, close system valves by pressing the Pressure Release softkey again. "Pressure Release" label turns red to indicate valves have closed.



Rinse

The rinse routine opens the section valves and runs the solution pump at full capacity. This flushes the entire system with clean water from pump inlet through the row units. Rinse the system whenever it won't be used again for several hours, including overnight. This prevents plugging of system components with chemical residue. Once started, the rinse routine will run until cancelled by the operator, a NO FLOW alarm that lasts longer than 15 seconds, or the Rinse Time expires. The Rinse Time can be adjusted by pressing the number and entering a new value before entering the Rinse routine.



Before starting Rinse Routine, make sure at least 3 gallons of water remain in the water tank.

Procedure:

1. Enter Charge/Rinse from Configurations screen by pressing the Charge/Rinse softkey.

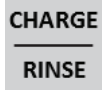

2. Enter the Rinse routine by pressing the Rinse softkey.



3. Begin the Rinse routine by pressing the HOLD softkey.



The system will pump clean water through the system. The rinse routine should run until all foam is dissolved, and water flows from each row. During the Rinse Routine, the SafeGuard Blockage Monitor will show blockages, due to the difference in density between water and foam.

4. Stop the Rinse routine by pressing the RUN softkey again.



5. Exit the Rinse routine by pressing the HOME softkey.



Rinse Screen

The screenshot shows the 'Rinse Screen' interface. At the top, there are 'ON' and 'OFF' buttons for 'SECTIONS' and a central valve icon. Below this are four numbered buttons (1, 2, 3, 4). A table displays 'Water' parameters: Pressure (0 PSI), Rate/Min. (0.0 oz/m), and Duty Cycle (0.0 %). To the right, there are 'Compressor 1' and 'Compressor 2' status indicators. At the bottom, 'Charge Time' is set to 5 and 'Rinse Time' is set to 15. On the right side, there are 'HOME' and 'CONFIGURE' icons, and a 'RINSE' button with a 'HOLD' icon below it.

Channel Setup - Operation



1 Enable Channel

This checkbox enables Channel 1 for normal operation. The default position is “enabled”.

2 Activity

This selection describes the controlled implement activity to the ISOBUS network. The default position is “Crop Protection”.

3 Target Rate (Total of Water + 3RIVE 3D Chemical)

Enter desired overall Target Rate for application. This number refers to the total of both Water and 3RIVE 3D chemical combined. Default Target Rate for 3RIVE 3D application is 32 oz/Acre of water + 8 oz/Acre of 3RIVE 3D chemical = 40 oz/Acre total Target Rate.

4 Rate Step

This setting defines the increment step of change per key press for Ch.1 Increase/Decrease buttons on the Home Screen. Default unit is 1 oz/Acre.

5 Material

This setting configures the control system for material. It is preset for Liquid application.

6 Material Units

This setting defines the system unit of measure. It is preset for Ounces.

7 Set PWM Limits

This button opens another screen that allows the operator to adjust PWM duty cycle limits. See page 46.

8 Fine Tune Meter

This button opens another screen that allows the operator to fine tune flowmeter calibration settings. This procedure only applies to Ch. 2. See page 47.

9 Home

VT Softkey - directly navigates to the Home screen.

10 Totals

VT Softkey - directly navigates to the Totals screen.

11 Configure

VT softkey - directly navigates to Configure screen.

12 Channel 2 Setup

VT softkey - directly navigates to Ch. 2 Setup.

Channel Setup - Implement

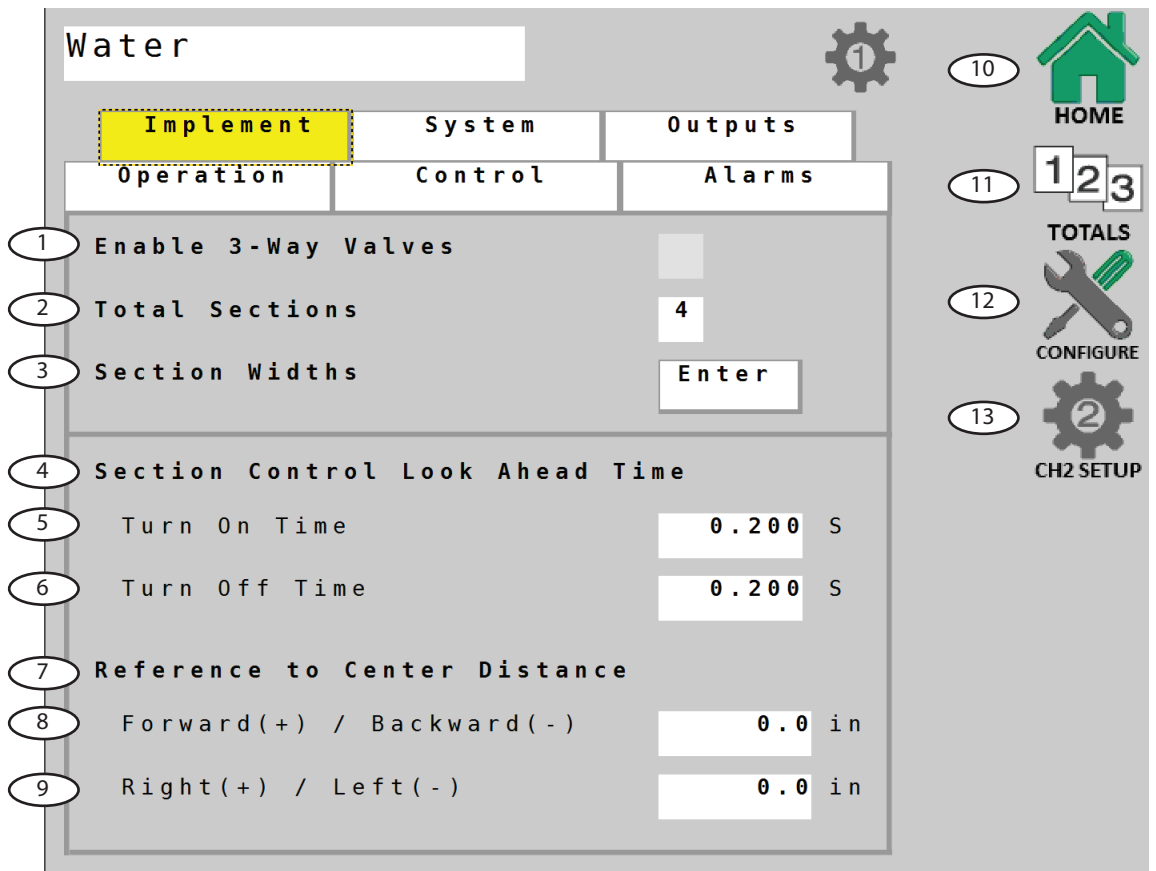

1 Enable 3-Way Valves

Enable 3-Way Valves is disabled for 3RIVE 3D operation.

2 Total Sections

Enter the total number of sections installed on the 3RIVE 3D system.

3 Section Widths

Enter the widths of sections - starting from left. To finish, press Implement tab to navigate back to Channel Setup.

4 Section Control Look Ahead Time

These controls allow the system to anticipate section valve activity when under Task Controller control. This effectively accounts for the time it takes for the valve to fully open or close.

5 Turn On Time

This setting is the number of seconds that the system will anticipate when turning section valve on. Default is .2 seconds.

6 Turn Off Time

This setting is the number of seconds that the system will anticipate when turning section valve off. Default is .2 seconds.

7 Reference to Center Distance

This measurement defines the distance from the Reference Point as specified in Configuration B to the center of the implement itself. If the center of the toolbar was specified as the Reference Point, then these values may remain at 0.

8 Forward (+) / Backward (-)

Measure the forward or backward distance from the Task Controller Reference Point to the center of the implement.

9 Right (+) / Left (-)

Measure the right or left distance from the Task Controller Reference Point to the center of the implement. If the implement has no offset, leave value at 0.

10 Home

VT Softkey - directly navigates to the Home screen.

11 Totals

VT Softkey - directly navigates to the Totals screen.

12 Configure

VT softkey - directly navigates to Configure screen.

13 Channel 2 Setup

VT softkey - directly navigates to Ch. 2 Setup.

Channel Setup - Control

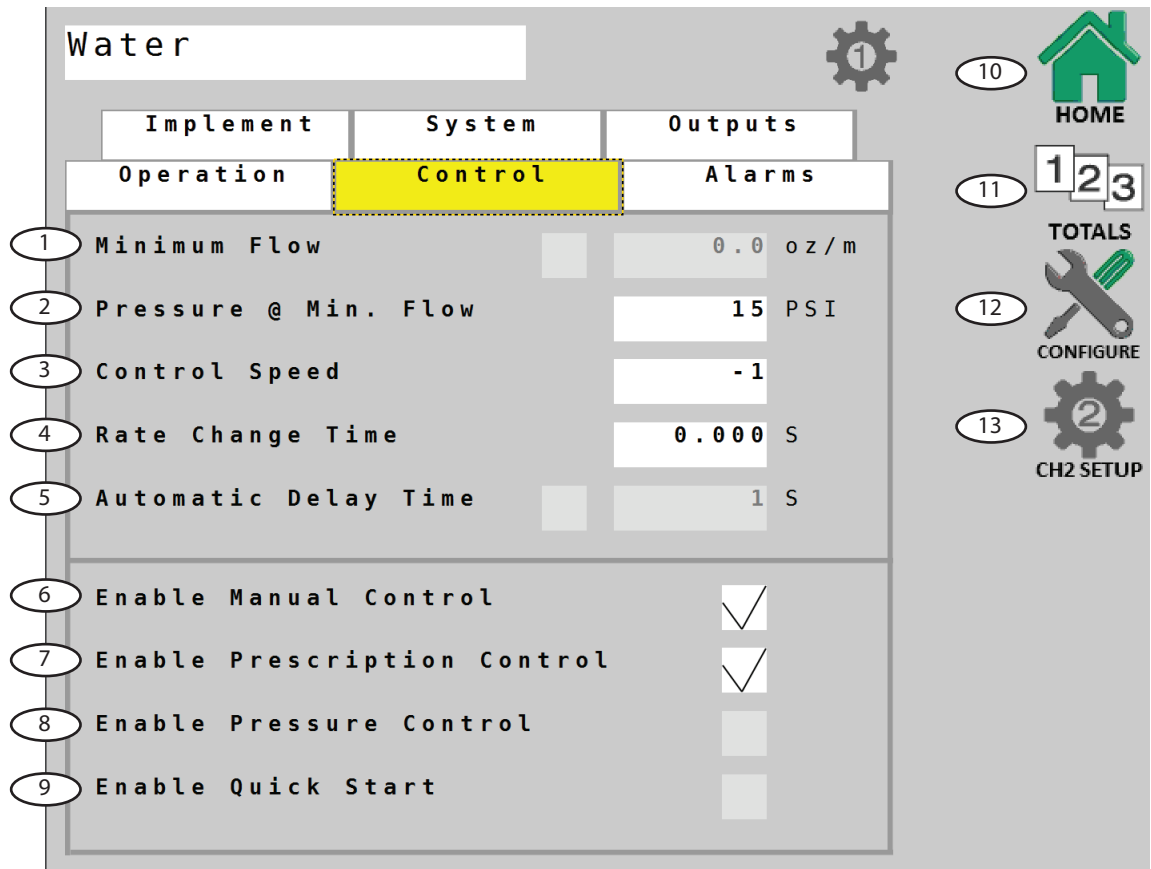

1 Minimum Flow

This setting is not used for 3RIVE 3D application.

2 Pressure @ Min. Flow

This setting is not used for 3RIVE 3D application. Do not adjust.

3 Control Speed

This value optimizes valve response time to fine-tune the system. The default setting is -1.

4 Rate Change Time

This control allow the system to anticipate application rate control activity when under Task Controller control. This accounts for the time it takes for the Task Controller to send, and the 3RIVE 3D Dual Plus ISOmod to respond to, rate change commands.

5 Automatic Delay Time

This setting is not used for 3RIVE 3D application.

6 Enable Manual Control

7 Enable Prescription Control

8 Enable Pressure Control

This setting is not used for 3RIVE 3D application.

9 Enable Quick Start

This setting is not used for 3RIVE 3D application.

10 Home

VT Softkey - directly navigates to the Home screen.

11 Totals

VT Softkey - directly navigates to the Totals screen.

12 Configure

VT Softkey - directly navigates to Configure screen.

13 Channel 2 Setup

VT Softkey - directly navigates to Ch. 2 Setup.

Channel Setup - System

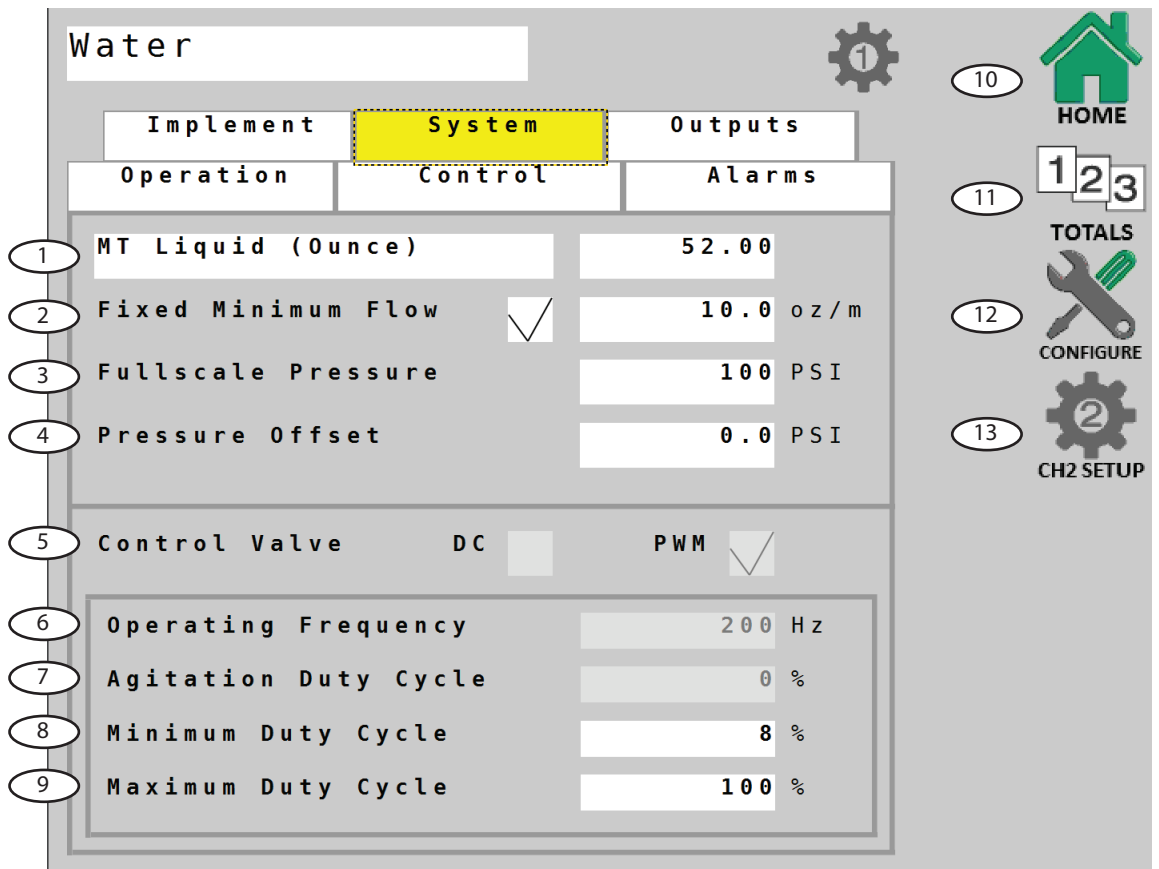

1 Flowmeter Units & Value

This position defines the flow pulse units and calibrates the system to the flowmeter factory setting. This number value is calculated specifically for the 3RIVE 3D system. If necessary, fine tune this value using the Fine Tune Flowmeter procedure described in **Channel Setup - Operation**.

2 Fixed Minimum Flow

Fixed Minimum Flow sets an absolute minimum value for flow. This ensures that the flow rate is never less than the lowest range of the flowmeter - preventing the flowmeter from stalling. Preset at factory.

3 Fullscale Pressure

Displays and adjusts FULL SCALE (maximum) value for Pressure Sensor. Default is 100 PSI.

4 Pressure Offset

Adjusts system to calculate pressure readings when using an "Absolute" style pressure sensor. Input Absolute Atmospheric Pressure in PSI (bar) for your location.

5 Control Valve

Control Valve setting is set to PWM operation as default for 3RIVE 3D operation.

6 Operating Frequency

Operating Frequency for PWM valve control is preset to 200 Hz for 3RIVE 3D operation.

7 Agitation Duty Cycle

This setting not used for 3RIVE 3D.

8 Minimum Duty Cycle

This setting is the PWM duty cycle low limit for the PWM controlled pump. If necessary, fine tune this value using the Set PWM Limits procedure described in **Channel Setup - Operation**.

9 Maximum Duty Cycle

This setting is the PWM duty cycle high limit for the PWM controlled pump. If necessary, fine tune this value using the Set PWM Limits procedure described in **Channel Setup - Operation**.

10 Home

VT Softkey - directly navigates to the Home screen.

11 Totals

VT Softkey - directly navigates to the Totals screen.

12 Configure

VT Softkey - directly navigates to Configure screen.

13 Channel 2 Setup

VT Softkey - directly navigates to Ch. 2 Setup.

Channel Setup - Alarms

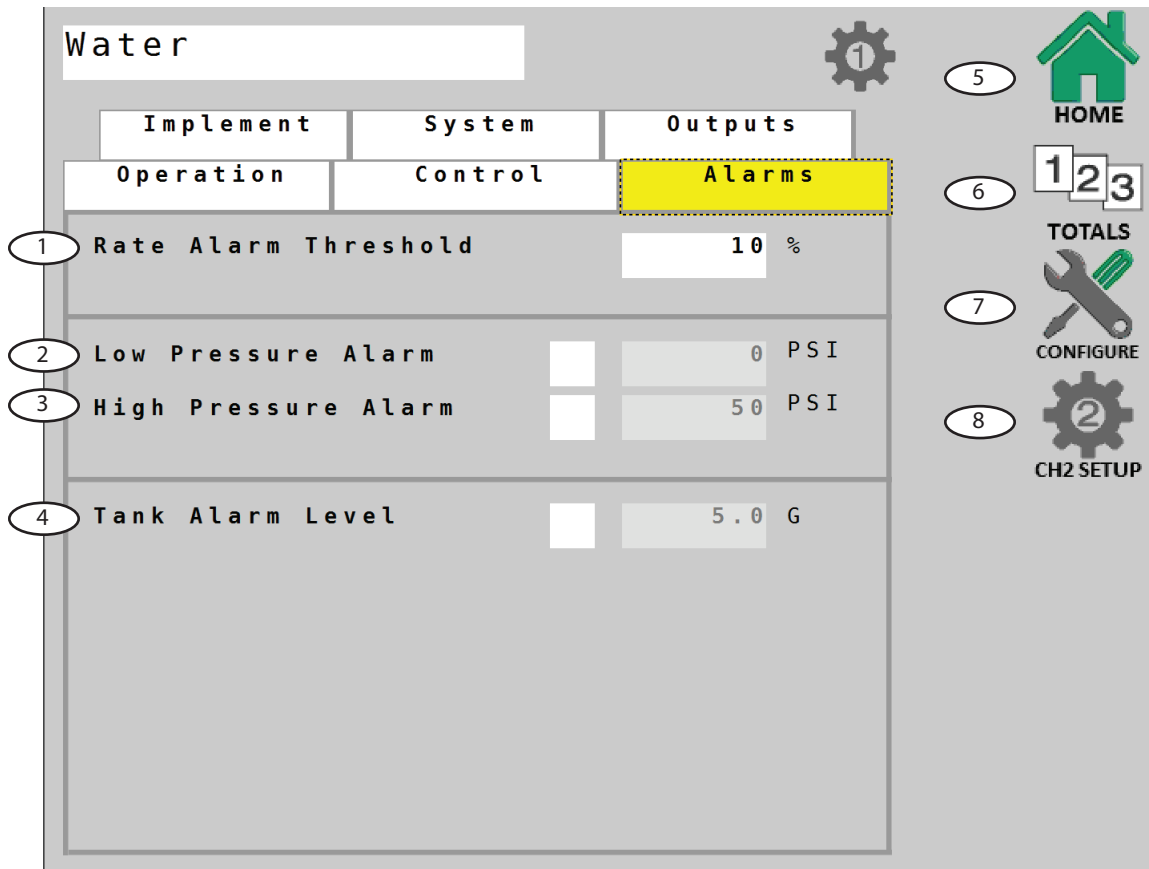

1 Rate Alarm Threshold

Adjusts threshold value for the Rate Alarm - can be set from 10-30%. This value is the percentage of difference between the actual rate of application and the intended (target) rate. Default setting is 10%.

2 Low Pressure Alarm

Enables and adjusts value for Pressure Alarm - set value to notify operator when low level is reached. Range: 0 to 50% of FULL SCALE setting.

3 High Pressure Alarm

Enables and adjusts value for Pressure Alarm - set value to notify operator when high level is reached. This can be set to OFF (0) or up to 100% of FULL SCALE setting.

4 Tank Alarm Level

This enables and specifies a value for the Tank Alarm. When enabled, the approximate value can be seen on the tank gauge display on the Home screen as a red line.

5 Home

VT Softkey - directly navigates to the Home screen.

6 Totals

VT Softkey - directly navigates to the Totals screen.

7 Configure

VT Softkey - directly navigates to Configure screen.

8 Channel 2 Setup

VT Softkey - directly navigates to Ch. 2 Setup.

Channel Setup - Outputs

Each channel on the 3RIVE 3D Dual Plus ISOmod has two assignable outputs, A & B. These are preset to control the air compressors. 3RIVE 3D systems with more than 24 rows will have 2 air compressors. Output B controls the 2nd compressor.

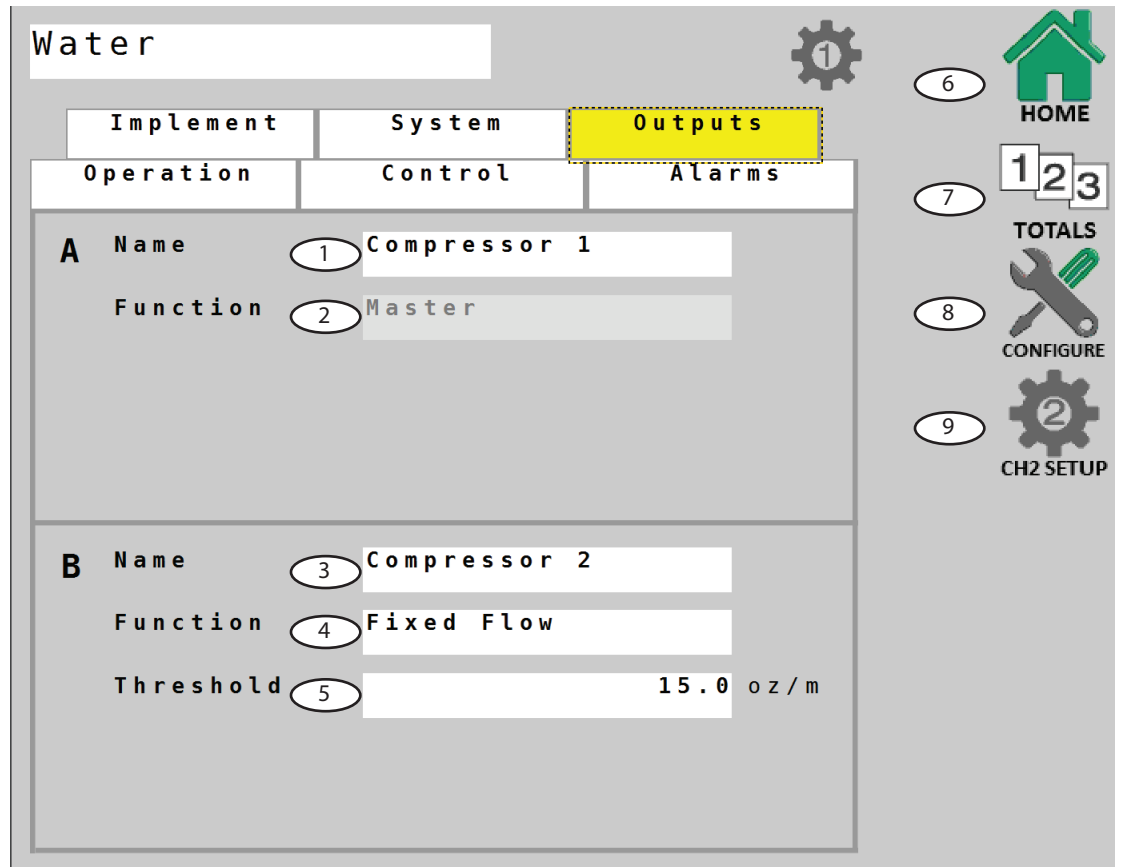

1 Name of Output A

Default name of this output is "Compressor 1".

2 Function

Default function of this output is preset to Master.

3 Name of Output B

Default name of this output is "Compressor 2".

4 Function

Default function of this output is preset to Fixed Flow. This turns on the 2nd compressor (if used) at a set flow rate.

5 Threshold

This is the threshold value assigned to turn on the 2nd compressor (if used). Default value for this setting is 15 oz./minute.

6 Home

VT Softkey - directly navigates to the Home screen.

7 Totals

VT Softkey - directly navigates to the Totals screen.

8 Configure

VT Softkey - directly navigates to Configure screen.

9 Channel 2 Setup

VT Softkey - directly navigates to Ch. 2 Setup.

Diagnostic 1

This tab contains a variety of information that is specific to the 3RIVE 3D Electronic Control Unit (ECU) - Serial Number, Hours etc. User editable parameters are shown below.

The screenshot shows a diagnostic interface with a title bar 'Diagnostic' and a green ECG icon. Below the title bar are two tabs, '1' and '2', with '1' selected. The main content area displays the following information:

```
Micro-Trak Systems, Inc.  
Manufacturer Code: 565  
MTSI Part #: 19020  
Serial Number:  
Hours:  
Current VT# 1  
ECU Instance: 0  
Device Class: (6) Sprayers  
Device Class Instance: 0  
Device Function: (128) Spray Rate Control  
Device Function Instance: 0  
ISO Name:  
SW IDs:
```

On the right side, there are three navigation icons: 'HOME' (house icon), 'CONFIGURE' (wrench and pencil icon), and 'DISCONNECT' (plug icon with an arrow). Each icon is numbered in a circle: 4, 5, and 6 respectively. The 'ECU Instance' field is also numbered with a circle containing '1'.

1 Ecu Instance:

Leave this value at 0 unless there are multiple ECUs of the same Device Class and Device Function on the bus. Set ECU Instance to 1, if there is a conflict.

2 Device Class Instance:

Leave this value at 0 unless there are multiple ECUs of the same Device Class on the bus. Set Device Class Instance to 1, if there is a conflict.

3 Device Function Instance:

Leave this value at 0 unless there are multiple ECUs of the same Device Function on the bus. Set Device Function Instance to 1, if there is a conflict.

4 Home

VT Softkey - directly navigates to the Home screen.

5 Configure

VT Softkey - directly navigates to the Configure screen.

6 Disconnect

VT Softkey - disconnects the 3RIVE 3D Dual Plus ISOmod from the ISOBUS network.

Diagnostic 2

Diagnostic tab 2 shows the raw data that is processed by the Electronic Control Unit to control the 3RIVE 3D system. It is displayed as a troubleshooting reference only.

The screenshot shows a 'Diagnostic' screen with a title bar and a green ECG icon. Below the title bar are two tabs, '1' and '2', with '2' highlighted in yellow. The main content area is divided into two columns: 'Solution' and 'Chemical'. Each column contains a list of parameters with their corresponding values. On the right side of the screen, there are three navigation icons: 'HOME' (a house icon), 'CONFIGURE' (a wrench and screwdriver icon), and 'DISCONNECT' (a green plug icon with a red arrow pointing away). Each icon is accompanied by a circled number: '1' for HOME, '2' for CONFIGURE, and '3' for DISCONNECT.

Solution	
Target Rate/Area	40.0
Actual Rate/Area	0.0
Area Per Hour	0.00
Active Width	0
% Error	0
Control Rate/Min.	0.0
Control Frequency	0.0
Pressure	0
PWM % Duty Cycle	0.0

Chemical	
Target Rate/Area	8.0
Actual Rate/Area	0.0
Area Per Hour	0.00
Active Width	0
% Error	0
Control Rate/Min.	0.0
Control Frequency	0.0
Pressure	0
PWM % Duty Cycle	0.0

1 Home

VT Softkey - directly navigates to the Home screen.

2 Configure

VT Softkey - directly navigates to the Configure screen.

3 Disconnect

VT Softkey - disconnects the 3RIVE 3D Dual Plus ISOmod from the ISOBUS network.

Periodic Maintenance

Chemical Pump Assembly

The metering tube should be changed before each season to ensure the highest level of accuracy. A worn tube will begin to under-apply as the tube walls become less resilient.

Metering Tube

You will not have to change tubing size unless you're significantly changing your application rate from the initial setup. The chemical pump uses a metering tube for precise metering of the chemical. There are three tubes available. Selection is based on ounces per minute required by the system. Each tube size has its own calibration value that's entered into channel 2 flow cal. This calibration value represents pulses per ounce measurement.

P/N	Description	Cal value
19893	3.2 METERING TUBE	2944
19894	2.4 METERING TUBE	5071
19895	1.6 METERING TUBE	10963

Changing metering tube



When working on system with active product follow all chemical handling rules and safety procedures! The solution released in this step contains active chemical. Dispose of released solution in an appropriate manner.

1. Disconnect the tube from the input and output tubes at the push-to-connect fittings.
2. Pull down on the front of the pump head to open the tubing jaws.
- 3.

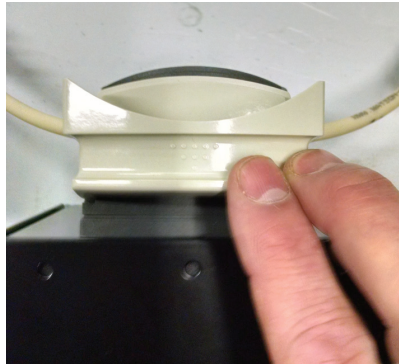

4. Lift up on tube to remove from pump jaws.



5. Lay the replacement tube into the jaws of the pump. The tube should be approximately centered on roller.



6. Gently close the jaws making sure the tube is centered in the V notch of the jaw cover.

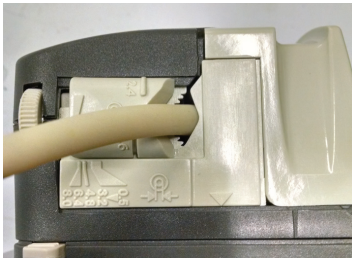

Cleaning Flowmeter

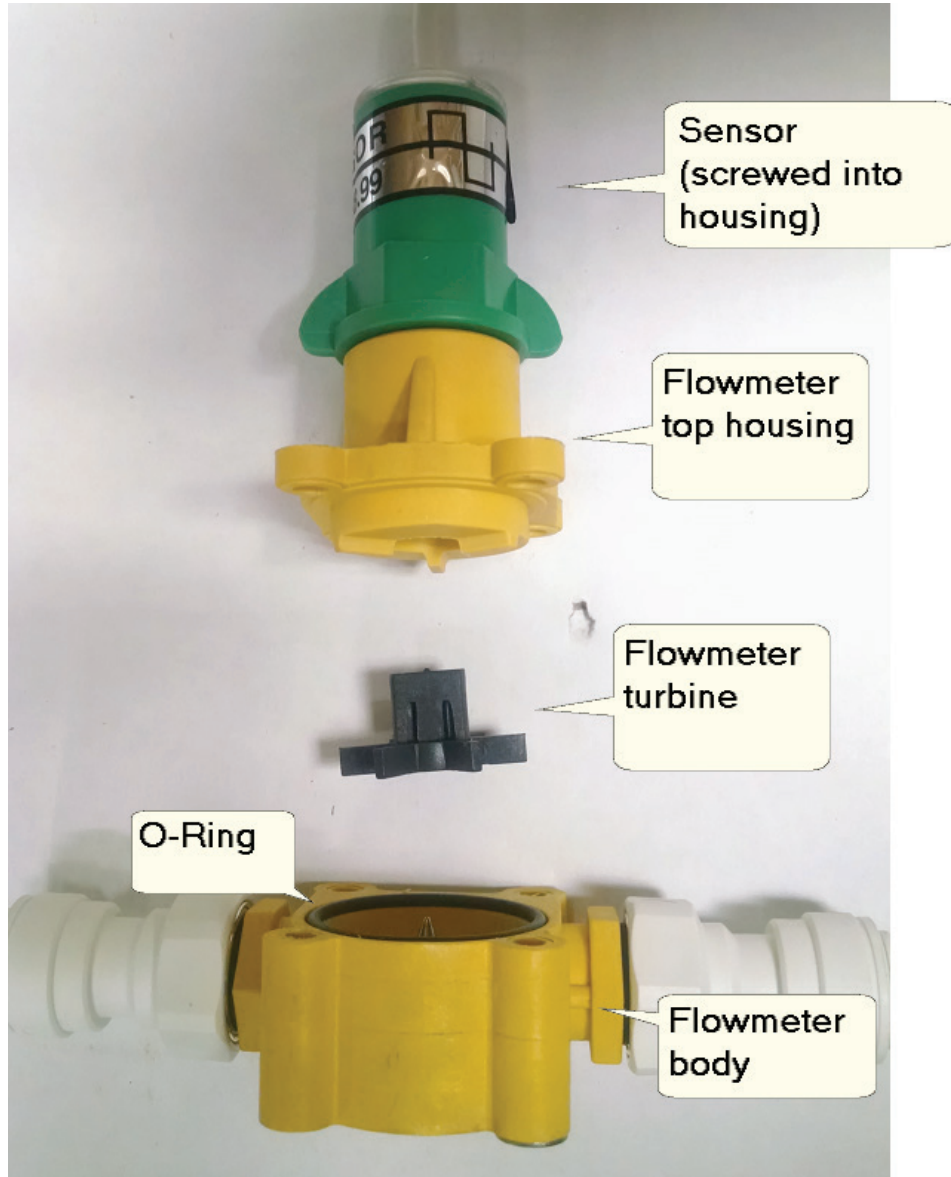

Flowmeter Cleaning Steps

1. Remove four nuts, screws and washers holding the top housing on the flowmeter body.
2. Remove the top housing from the flowmeter body.
3. Remove the turbine.
4. Clean any dirt or debris from the turbine, Turbine support pin , and flowmeter housing.
5. Reinstall turbine on top of support pin.
6. Reinstall top housing making sure O-ring is correctly placed in groove on flowmeter body.
7. Reinstall four nuts, screws and washers.
8. The flow sensor should be screwed completely into the top housing, finger tight.

Manifold Assembly

Liquid Inlet

The water/chemical solution enters the manifold at the side of the mixing tee. The spray pattern of the liquid is controlled by a Tee Jet spray tip core and stainless steel orifice disc.

When cleaning, remove both the core and orifice plate and make sure they are free of chemical residue. Ensure the nylon ore is not distorted and the holes in both the core and orifice plates are clear. Make sure they are oriented properly when reinstalling as shown below.

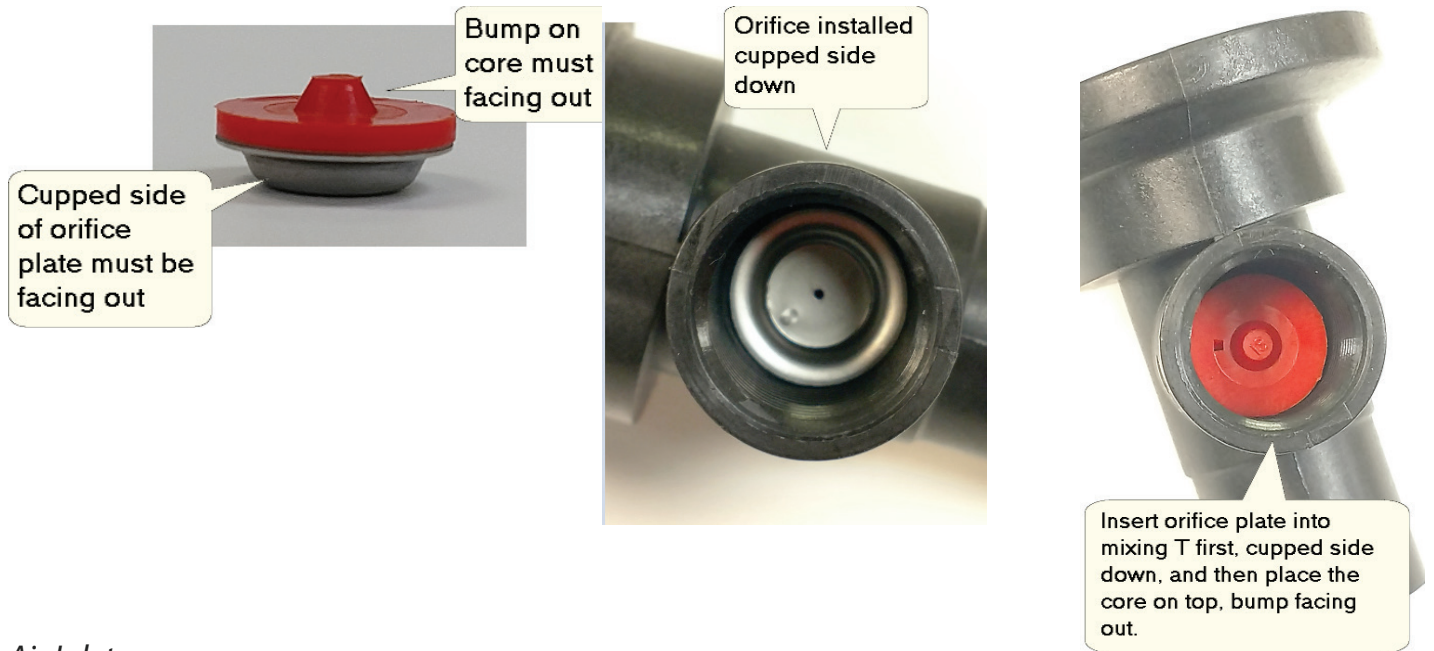

Air Inlet

The air enters the manifold at the bottom of the mixing tee. The volume and velocity of the air is controlled by a Tee Jet flat orifice plate. The orifice plate is installed in an EPDM rubber seal as shown below.



The air inlet also has a check valve which prevents liquid from filling the air line when the system is off. Put the disc with seal into the mixing tee first, with the check valve installed last.

Make sure the orifice plate hole is clear, and the check valve is free of sediment.

Section valves

The manifold assembly uses 1/4" ball valves to turn the section on or off. These are three wire ball valves.

Pin A – constant 12 VDC – always present.

Pin B – ground

Pin C – switched 12 VDC – when present the valve opens. When removed the valve closes.

End of Season Storage/ Winterization

 The 3RIVE 3D™ Application System uses water as a carrier component, and the chemical contains ingredients that can cause clogging if allowed to settle out / dry within the system. The entire system **MUST BE THOROUGHLY RINSED AND WINTERIZED** prior to storage.

Perform a RINSE routine of at least 15 minutes duration prior to winterization to ensure the system is clean and free of any chemical residue.

Note: Even if the system is stored in a heated building, it is imperative that the chemical tank and strainer are cleaned, and a full clean water rinse routine is performed prior to storage. Failure to clean out all chemical residue will cause malfunctions due to sediment and residue.

	Drain the chemical tank and chemical strainer and rinse out residual chemical and debris with clean water making sure tank is empty when complete.
	Dispose of all chemical and rinsate/waste water in the proper manner.
	Perform a RINSE routine with clean water of at least 15 minutes duration to ensure the system is clean and free of any chemical residue.
	Pour 1 gallon of RV antifreeze in the chemical tank and 3 gallons in the water tank.
	Run a CHARGE routine, followed by another RINSE routine. This will fill both chemical and water sides of the system with RV antifreeze. Run the RINSE routine until RV antifreeze is seen in the SafeGuard chambers and is running out of the row units.
	The system is now ready for storage.

Cold Evening Procedure

 **Important!** The 3RIVE 3D™ Application System uses water as a carrier component which freezes at 32 degrees F. The Capture 3RIVE 3D™ component is safe to temperature of 27 degrees F. To avoid damage caused from freezing the system should be parked indoors or the procedure below should be implemented if night time temps are expected to be below freezing.

Follow procedure for **End of Day Rinsing** with the following changes. Prior to starting rinsing procedure:

Drain all water from clean water tank. Add 2 gallons of RV antifreeze to the clean water tank. Run RINSE routine until tank is empty (routine will stop when tank is empty). RV antifreeze should be seen in all SafeGuard sensor chambers.







NOTE: Windshield washer fluid with a suitable below freezing rating can be used in lieu of RV antifreeze.

Troubleshooting

This troubleshooting guide covers common error messages that may be seen on the 3RIVE 3D™ system.

Pumps Not Running

Check LEDs on Electric Motor Driver modules connected to the pump motors. The status indicator is located in the center of the module.

LED STATUS INDICATOR CODES		
Light on steady		Unit is turned on and operating normally
Steady Flashing		Standby mode. Main power present, waiting for command from controller.
1 Flash/pause		Open circuit detected. Check motor connections for open.
2 Flashes/pause		Output short circuit detected. Check motor wiring.
3 Flashes/pause		Over-current condition. Check total load.
4 Flashes/pause		Input Power fault. Check input power wiring.
5 Flashes/pause		Input frequency out of range.
NOTE: Cycle power with the controller ON/OFF switch to clear a fault code		

Signal status LEDs are located in the corner of the module. One LED will be illuminated when there is a PWM control signal present. This LED will get brighter as the signal increases (running pump faster) and dimmer (slowing pump speed) as the control signal decreases.

If your module does not have center status LED, verify supply voltage at main power input connection to module.

No Speed

A NO SPEED message indicates there's no feedback from the speed sensor. If the vehicle is moving and there's a NO SPEED indication, check the following:

Astro GPS speed sensor (if installed)

The Astro GPS has a module near the connector. This module has two red indicators.

- Both indicators off
 - Verify there's 12 volts DC at the harness connection between pins C (ground) and B (power).
 - If power is present, replace GPS sensor
- One indicator on steady, the other is off
 - Replace GPS sensor
- One indicator on steady, the other is flashing
 - GPS trying to acquire signal. Make sure GPS sensor has clear view of sky (i.e. not in building). If flashing does not stop after two minutes replace GPS sensor

The Astro GPS sensor is repairable part and can be returned to Micro-Trak for a repair evaluation.

Checking for possible harness or connectivity problem:

Pin A – Signal

Pin B – Power

Pin C – Ground

- Check for 9 volts DC between pins A and C. Pin A is the signal input to the console.
- Check for 12 volts DC between pins B and C. Pin B is the power to the sensor.
- Turn the knob to SPEED. Tapping between pins A and C simulates pulses coming from the sensor. You should get an erratic reading on the console if it is receiving these pulses.

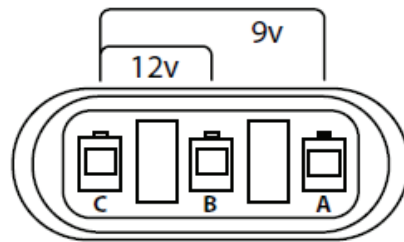

If voltage and tap test are good, this usually indicates a bad sensor.

No Flow

A NO FLOW message indicates no flow signal from the flowmeter when liquid flow is expected.

Testing channel 1 flowmeter sensor

1. Unscrew flow sensor from flowmeter body.
2. With console turned on, place sensor flat against a ferrous metal plate. A red LED should illuminate beneath the clear top cover. Does the red LED turn on when placed against metal plate, and turn off when moved away?
 - Yes – If this checks good, proceed to pulse test
 - No - sensor is malfunctioning, replace.

Pulse test

Place sensor flat against metal bracket. Red LED should turn on.

Move sensor away from plate. LED should turn off. Repeat this several times rapidly (simulating pulses from flowmeter). This should produce an erratic reading under channel 1 volume per minute display.

If this produces erratic reading on console, the sensor and cabling to the controller are good. Disassemble and clean flowmeter. If it does not, proceed with tap test as outlined below in *possible harness or connectivity problem* procedure.

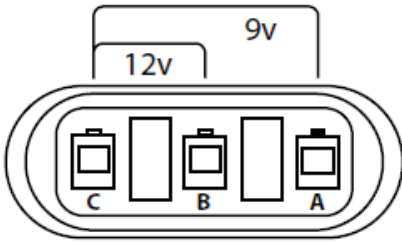

Checking for possible harness or connectivity problem:

Pin A – Signal

Pin B – Power

Pin C – Ground

- Check for 9 volts DC between pins A and C. Pin A is the signal input to the console.
- Check for 12 volts DC between pins B and C. Pin B is the power to the sensor.
- Turn the knob to VOLUME/MINUTE. Tapping between pins A and C simulates pulses coming from the sensor. You should get an erratic reading on the console if it is receiving these pulses.

If voltage and tap test are good, this indicates a bad sensor.

Testing channel 2 flow sensor

Channel 2 uses feedback from an internal encoder on the chemical pump. Perform connection and tap test as outlined above in *possible harness or connectivity problem* procedure. If tap test and voltages check ok, return pump assembly for repair.

3RIVE 3D™ Product Delivery



When testing system with active product follow all chemical handling rules and safety procedures! The solution released in this step contains active chemical. Dispose of released solution in an appropriate manner.

No foam – single rows

Put the system in CHARGE mode. Cycle the system from HOLD to RUN.

Can you hear row shutoff valve operating?

Yes – Place the system in HOLD and remove liquid tube from output of row shutoff valve.

Place the system in RUN. Does liquid flow from row shutoff valve output?

Yes – check for plugged or kinked row unit tubing

No – Verify liquid is present at row valve input.

No – If 12 VDC is present on pins A & C at connector when the system is in RUN, replace valve. If 12 VDC is not present, troubleshoot wiring.

Pin A – constant 12 VDC (needed to close valve. Always present)

Pin B – ground

Pin C – switched 12 VDC (12 volts present opens valve)

No foam – entire single section

Is liquid bubbling up in the section manifold SafeGuard™ sensor tubes?

Yes – Is there air pressure present at the tube going into the section air shutoff valve?

Yes – Verify manifold air inlet screen and orifice are clean. Verify fittings on manifold are not leaking

No – Troubleshoot kinked or leaking air tube.

No – Verify operation of section liquid shutoff valve. Place the system in CHARGE mode, Cycle the system between HOLD and RUN mode. Can you hear the valve operating?

Yes – Place the system in HOLD. Remove liquid tube from output of section shutoff valve. Place the system in RUN. Does liquid flow from shutoff valve output?

Yes – Verify section manifold liquid inlet orifices are clean. Check for plugged or kinked tubing

No – Troubleshoot liquid supply line for kinks or leaks.

No – If 12 VDC is present on pins A & C at connector when the system is in RUN, replace valve. If 12 VDC is not present, troubleshoot wiring.

Pin A – constant 12 VDC (needed to close valve. Always present)

Pin B – ground

Pin C – switched 12 VDC (12 volts present opens valve)

No foam – entire planter

Is there liquid bubbling up in the section blockage sensor tubes?

Yes – Is there air pressure at the air regulator?

Yes – Verify section air shutoff valves are operating. If not, troubleshoot wiring.

No – Is the air compressor running?

Yes – Check for kinked or disconnected air line between compressor and air regulator manifold.

Verify air is being supplied by compressor.

Verify air compressor relief shutoff valve is not stuck on. This will vent compressor output to outside system.

No – Verify LED is lit on relay module indicating “ON” condition. Check for power at output of relay module. If green LED on relay module is lit and there’s no 12 VDC at output, check fuse at battery connection.

No – Verify tank shutoff valves are open. Verify both pumps are running. Check channel 1 pressure. If pressure is building very high (> 60 psi) check section liquid shutoff valves for proper operation.

SafeGuard™ Blockage Monitor

The SafeGuard™ system is an electronic blockage monitor used to monitor flow of 3RIVE 3D foam.

Components

SafeGuard™ Console (stand alone)

This is the main control unit of the SafeGuard™ system. It continually scans for a blocked indication.

SafeGuard™ ISOmod

This is the main control unit of the SafeGuard™ system - designed for integration into ISOBUS. It continually scans for a blocked indication. Controls and operating information are found on the appropriate virtual terminal connected to the ISOBUS network.

SafeGuard™ Sensor

The sensor assembly is a liquid flow chamber surrounded by a blockage detection shroud. The bottom openings of the sensor assembly accommodate a variety of plugs (male) and caps (female). The chamber contains a detection cartridge which rises with flow, and drops when flow is interrupted.

Implement Switch & Module

SafeGuard™ can accept an optional Implement Switch and Module. This option silences the audible alarm on the SafeGuard™ when the implement is not in use. The Module provides the interface between an implement switch and SafeGuard™ wiring and can be placed at any point in the chained sensor connections.

Normal Operation - Console

When SafeGuard is turned on, it searches for sensors and implement switch modules installed on the data line.

During the power up sequence the console version displays the number of sensors found, for example: S 48 indicates 48 sensors were detected during power up. If the number of detected sensors has changed since the last power-up sequence, the console will pause, display the new sensor count, and beep to alert the operator.

Operator must acknowledge the new sensor count by pressing either volume button to continue the power-up sequence.

Devices are numbered sequentially based on their position on the data line starting with # 1 being closest to the console end of the cable.

Sensors and implement switch modules are numbered separately so the first implement switch module on the data line is always module # 1.

The console continually monitors the sensors for a blocked indication. When a blockage is detected the console immediately alerts you by flashing the red warning LED, sounding an audible alarm, and displaying the number of the sensor that is blocked. This alert will remain until the blockage is cleared. With the implement switch activated the display should show that all runs are blocked, and HOLD is displayed (audible alarm muted). This serves as confirmation that the system is working properly.

Troubleshooting

Display freezes during startup

When the console is turned on it searches for sensors and implement switch modules installed on the data line. During the power up sequence the console displays the number of sensors found, for example: S 48 indicates 48 sensors were detected during power up. If the number of detected sensors has changed since the last power-up sequence, the console will pause, display the new sensor count, and beep to alert the operator. **Operator must acknowledge the new sensor count by pressing either volume button to continue the power-up sequence.**

Console won't turn on

Is there power on the console power cable? Pin A is +12 VDC, Pin B is ground.

1. **NO** Troubleshoot for possible blown fuse, broken wiring or bad connections on power cable. Verify there's power at cable connection point.
2. **YES** Disconnect data cable and try to turn on the console. If it turns on with data cable disconnected troubleshoot damaged cable or sensor assembly. If it does not turn on with data cable disconnected, replace console.

Sensors Not Detected

3. **Several sensors in a row missing** - Check connection between last good sensor and first bad sensor. Bypass first bad sensor in string with extension cable or adjacent sensor leads.
4. **Single sensors not detected** - Isolate or verify bad sensor by bypassing suspect sensor with extension cable or sensor leads. Cycle power on console to re-scan for sensors.

Sensor not detecting blockage

If the cartridge is at the bottom of the sensor assembly and the sensor does not indicate BLOCKED, verify cartridge is in the sensor tube with tail on top/ball on bottom. If this is correct, replace sensor.

Sensor doesn't read GOOD

Remove cartridge from sensor chamber. If sensor doesn't read good with cartridge removed, replace sensor.

Open

No sensors detected during power up sequence. Check connection and cables between console and first sensor.

Net

Displayed when operating and communication with all sensors is lost

Error

Sensor was present at power-up, and is now not talking to the console. The sensor number will be displayed. If an H is displayed the error is originating from an implement switch module. The number of the module will be displayed.

Appendix A – Default Settings

NOTE: These settings are based on requirements for a 24-row planter

	Applies to both Ch. 1 & 2	
Configuration	English	Metric
Speed Source	Remote	Remote
Speed Cal (inches/cm)	0.189	0.48
Alarm Minimum Speed (mph/km/h)	0.0	0.0
Area Units	Acres	Hectares
Mode	Injection	Injection
Quick Start Speed (mph/km/h)	Blank (0.0)	Blank (0.0)
Quick Start Time (seconds)	Blank (0)	Blank (0)
Test Speed (mph/km/h)	5.0	8.0
Implement Switch Polarity (Run =)	Close	Close
Implement Switch External Source	Local (None)	Local (None)
Automatically attach Task Controller	Disabled	Disabled
Enable Section Control	Enabled	Enabled
Hitch to Reference (In/mm) Forward/Backward	0.0	0
Hitch to Reference (In/mm) Right/Left	0.0	0
Hitch Type	Unknown	Unknown
Configuration Lock	Unlocked	Unlocked
Charge Time (Minutes)	5	5
Rinse Time (Minutes)	15	15

	Channel 1		Channel 2	
Operation	English	Metric	English	Metric
Product Name	Water	Water	3RIVE 3D	3RIVE 3D
Enable channel	Enabled	Enabled	Enabled	Enabled
Material (H2O/NH3)	H2O	H2O	H2O	H2O
Material Units (oz, gallons/ ml, liters)	Oz	MI	Oz	MI
Target Rate (oz/acre / ml/ha, etc)	40	480	8	95
Rate Step (oz/acre / ml/ha, etc)	1	10	1	5
Activity	Crop Protect.	Crop Protect.	Crop Protect.	Crop Protect.
Control				
Minimum Flow Enable (Proportional)	Disabled	Disabled	Disabled	Disabled
Minimum flow (oz, gallon, etc.)	0	0	0	0
Minimum Pressure Enable	Disabled	Disabled	Disabled	Disabled
Minimum Pressure (PSI/Bar)	15	1.00	15	1.00
Control Speed (-12 to 3)	-1	-1	-1	-1
Rate Change Time (seconds)	0.000	0.000	0.000	0.000
Automatic Delay Enable	Disabled	Disabled	Disabled	Disabled
Automatic Delay Time (seconds)	1	1	1	1
Enable Manual Control	Enabled	Enabled	Enabled	Enabled
Enable Prescription Control	Enabled	Enabled	Enabled	Enabled
Enable Pressure Control	Disabled	Disabled	N/A	N/A
Enable Quick Start	Disabled	Disabled	Disabled	Disabled

Alarms				
Rate Alarm Threshold (%)	10	10	10	10
Low Pressure Alarm Enable	Disabled	Disabled	Disabled	Disabled
Low Pressure Alarm (psi/Bar)	0	0	0	0
High Pressure Alarm Enable`	Disabled	Disabled	Disabled	Disabled
High Pressure Alarm (psi/bar)	50	3.40	50	3.40
Tank Alarm Enable	Disabled	Disabled	Disabled	Disabled
Tank Alarm Level (Gallons/liters)	5 Gallons	20 Liters	1 Gallons	4 Liters
Tank Fill Level (Gallons/liters)	130 Gallons	500 Liters	30 Gallons	115 Liters
Outputs				
Output A Name	Compressor 1	Compressor 1	N/A	N/A
Output A Function	Master	Master	Not Used	Not Used
Output A Threshold (oz/m,ml/m,etc.)	0	0	0	0
Output A Flush Time (seconds)	5	5	5	5
Output A Flush Delay (seconds)	3	3	3	3
Output B Name	Compressor 2	Compressor 2		
Output B Function	Fixed Flow	Fixed Flow	Not Used	Not Used
Output B Threshold (oz/m,ml/m,etc.)	15	450	0	0
Output B Flush Time (seconds)	5	5	5	5
Output B Flush Delay (seconds)	3	3	3	3
System				
Flow Calibration Units	MTS Ounces	MTS Ounces	MTS Ounces	MTS Ounces
Flow Calibration	52	52	5071	5071
Fixed Minimum Flow Enable	Enabled	Enabled	Enabled	Enabled
Fixed Minimum Flow (oz/ml/etc.)	10	295	1	30
Full Scale Pressure (PSI/Bar)	100	6.9	100	6.9
Pressure Offset (PSI/Bar)	0.0	0.00	0.0	0.00
Control Valve (DC/PWM)	PWM	PWM	PWM	PWM
Frequency (Hz)	200	200	200	200
Agitation (%)	0	0	0	0
Minimum Pulse Width (%)	8	8	8	8
Maximum Pulse Width (%)	100	100	100	100
Valve Polarity	In Line	In Line	In Line	In Line
Auto Shutoff	Disabled	Disabled	Disabled	Disabled
Implement				
Enable 3-Way Valves	Disabled	Disabled	Disabled	Disabled
Total Sections	4	4	1	1
Section 1 Width (inches/Meters)	180	4.600	720	18400
Section 2 Width (inches/Meters)	180	4.600	N/A	N/A
Section 3 Width (inches/Meters)	180	4.600	N/A	N/A
Section 4 Width (inches/Meters)	180	4.600	N/A	N/A
Section 5 Width (inches/Meters)	120	3.048	N/A	N/A
Section 6 Width (inches/Meters)	120	3.048	N/A	N/A
Section 7 Width (inches/Meters)	120	3.048	N/A	N/A

Section 8 Width (inches/Meters)	120	3.048	N/A	N/A
Section 9 Width (inches/Meters)	120	3.048	N/A	N/A
Section 10 Width (inches/Meters)	120	3.048	N/A	N/A
Section 11 Width (inches/Meters)	120	3.048	N/A	N/A
Section 12 Width (inches/Meters)	120	3.048	N/A	N/A
Turn On Time (seconds)	0.200	0.200	0.200	0.200
Turn Off Time (seconds)	0.200	0.200	0.200	0.200
Ref to Center - Forward/Backward (in/mm)	0.0	0	0.0	0
Ref to Center - Right/Left (in/mm)	0.0	0	0.0	0

Appendix B – Wiring Diagrams

Bulkhead Harness - PN 19298

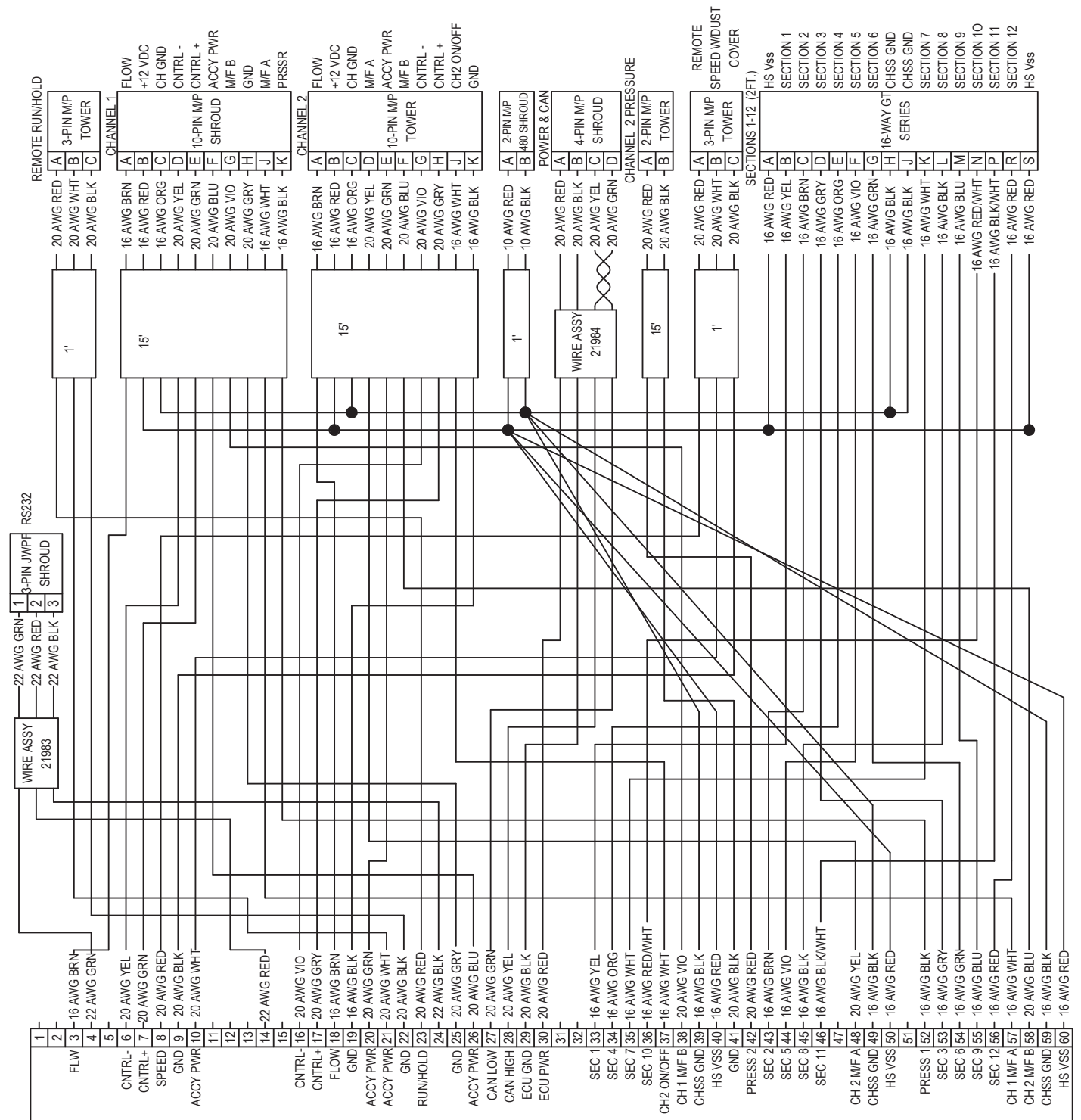

Channel 1 Branch - PN 19285

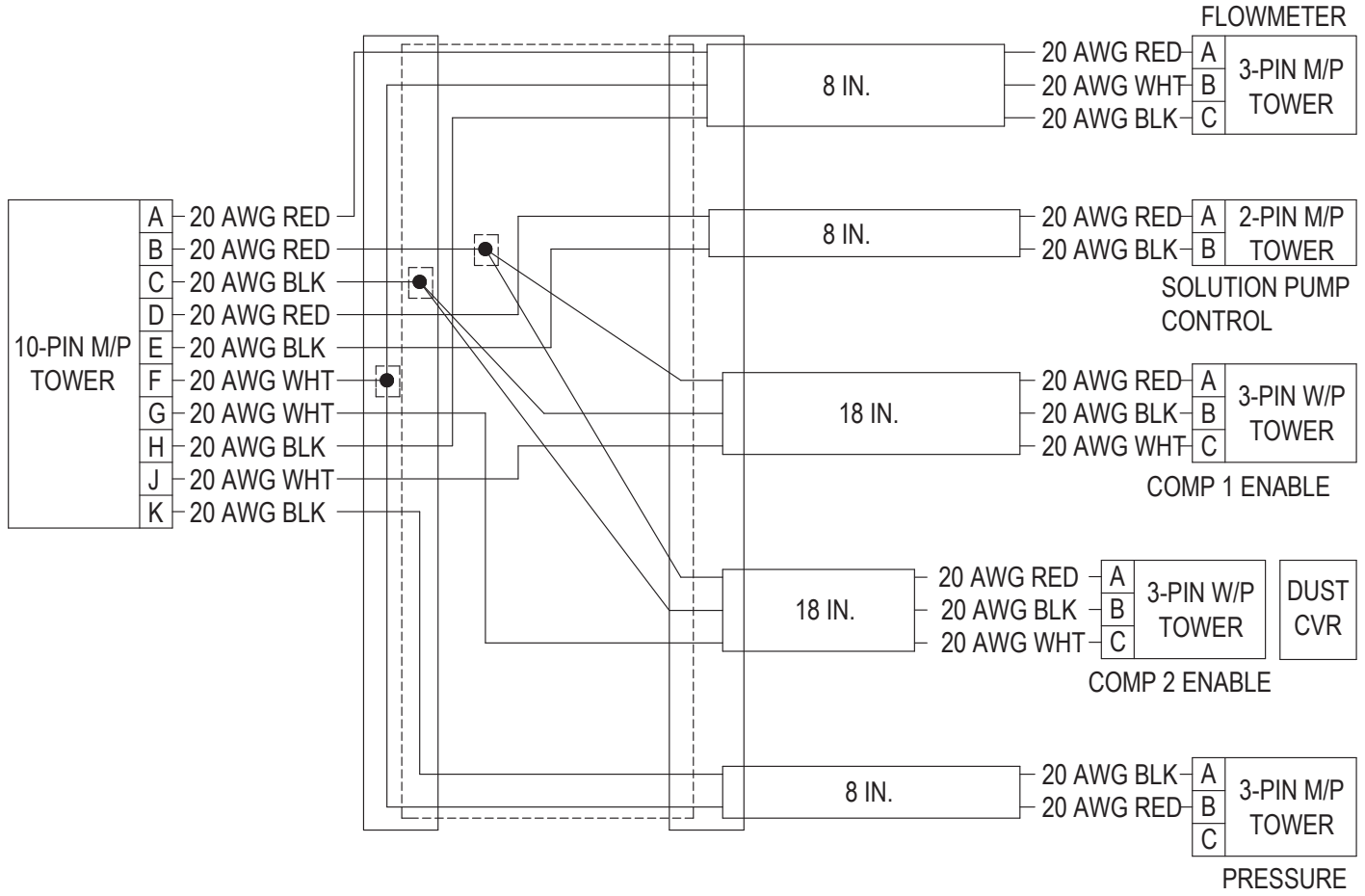

Channel 2 Branch - PN19287

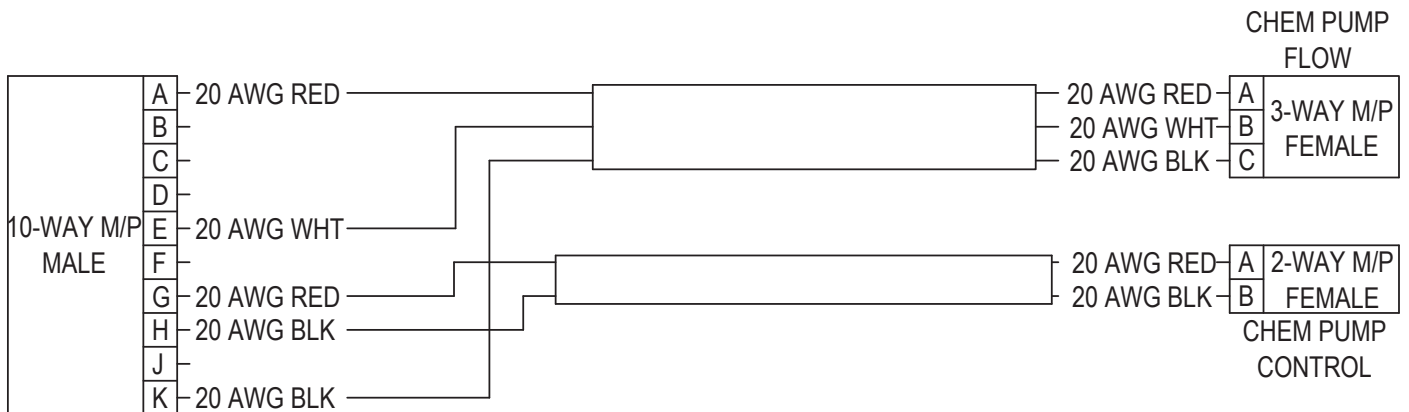

Section Harness Examples

Valve Connections
 Pin A – constant 12 volts DC
 Pin B – ground
 Pin C – switched 12 volts DC

PN 19324 - 4 Section Harness

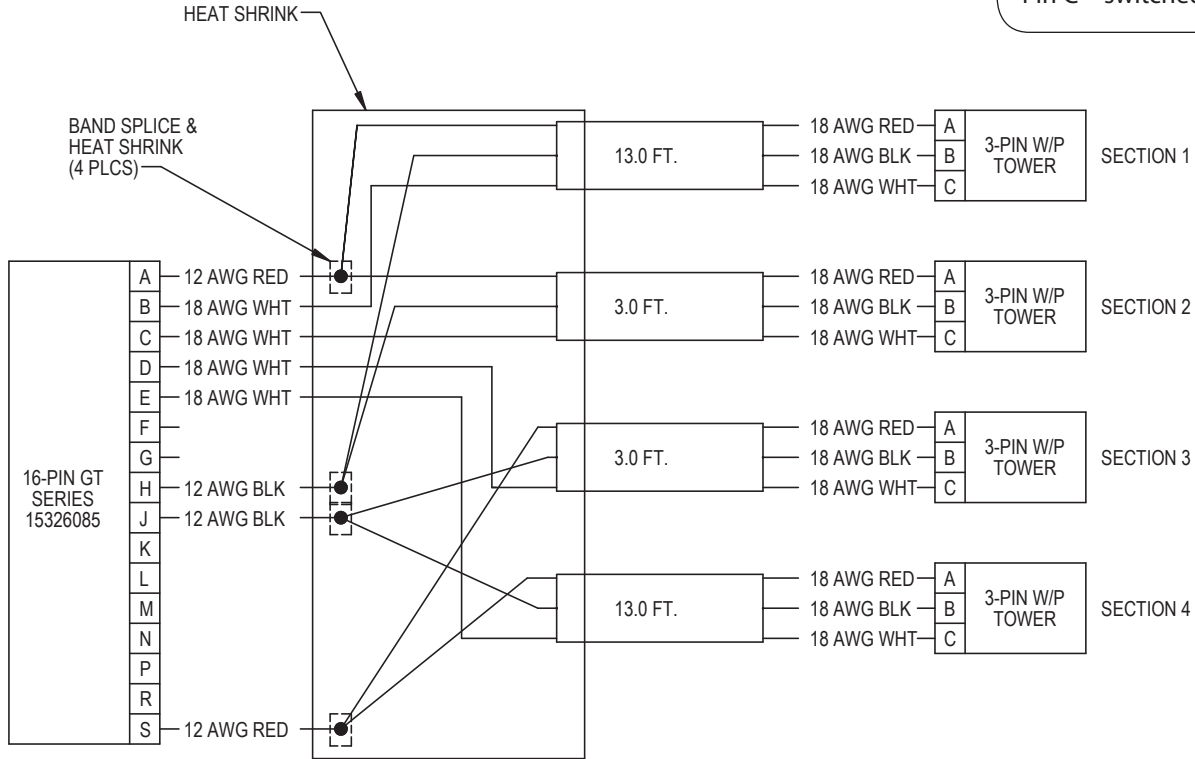

PN 19326 - 6 Section Harness

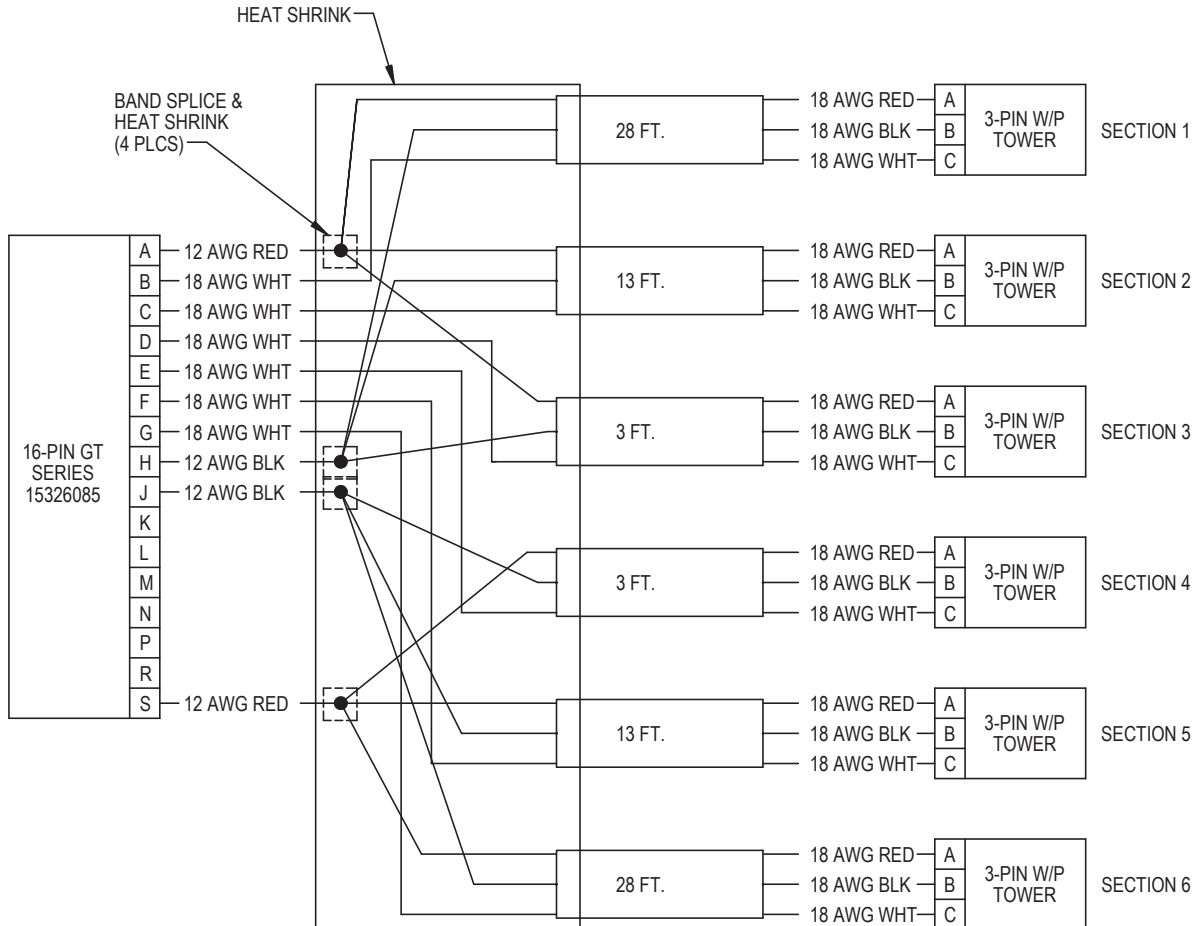

Appendix C

Channel Setup - Set PWM Limits

This setup routine establishes low and high PWM duty cycle limits for the PWM controlled pump.

Procedure:

Set Minimum Limit

1. With at least one section turned on, press the Run/Hold softkey.



2. Press the Increase button until the pump shows steady minimum motion. Data window on the right shows real-time duty cycle %.



3. To save this value as the new minimum duty cycle %, press the Minimum button onscreen.

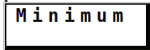

Set Maximum Limit

4. Press the Increase button until maximum pump speed is reached. Data window on the right shows real-time duty cycle %.



5. To save this value as the new maximum duty cycle %, press the Maximum button onscreen.

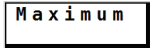

Save Changes, and Exit

6. Press Run/Hold softkey to stop pump.



7. Press Confirm softkey to save changes and exit back to Channel Setup.

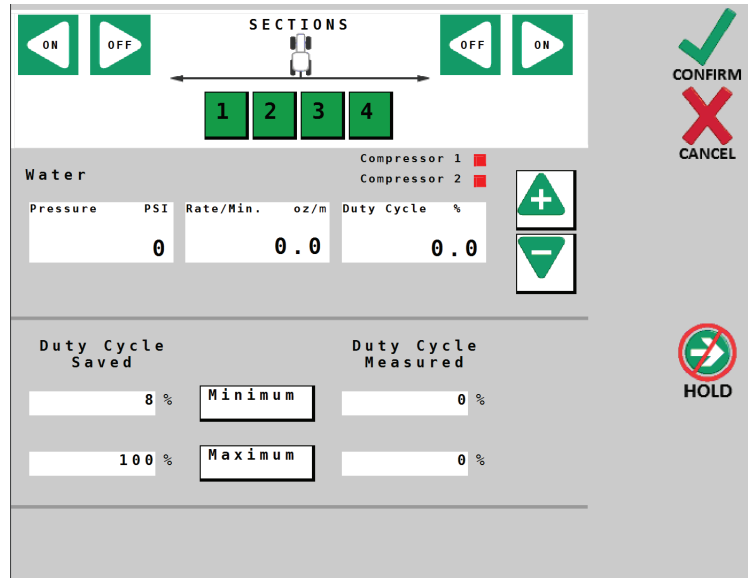

Appendix D

Channel Setup - Fine Tune Meter (Ch. 2 - chemical)

This Fine Tune Meter procedure is only intended for Channel Two / Chemical.



When working on system filled with 3RIVE 3D chemical, follow all chemical handling rules and safety procedures!

This procedure is used to verify and fine-tune the flow calibration by catch test. The catch test result is then compared with the system calculated volume, and the system is then adjusted to match actual flow. The larger the sample of water, the more precise the test and adjustment will be. The default unit for the system is ounces, so a beaker marked in ounces is preferable. If the product is collected in a gallon container, multiply gallons collected by 128 to get the ounces collected - 1 quart collected = 32 ounces on display.

Note: the Fine Tune Meter test is automatically preset to run at simulated speed of 6 mph, using the current Target Rate and Active Width.

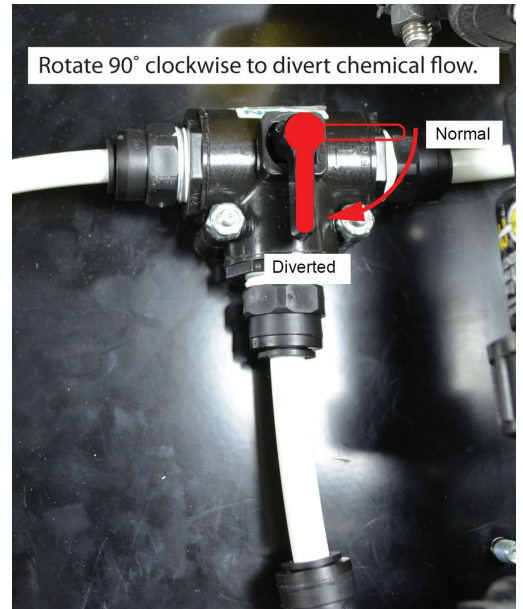

Test Procedure:

1. Remove Pump-pak front cover.
2. Place the calibration tube into a graduated container to collect the chemical. If a clean container is used, the chemical collected can be put back into the chemical tank when test is complete.
3. Rotate 3-way valve handle 90° clockwise to divert chemical to catch test container. See photo.
4. Press Run/Hold softkey when all catch test containers are in place. At least one section must be active.



5. Run test until intended volume is reached.
6. Press Run/Hold softkey to stop flow.



7. Measure collected liquid and enter total Volume Measured in box on screen. Press on the number to enter the number.

Volume Measured	oz
0.0	

8. The new value is automatically calculated, and then displayed in the Meter Cal Calculated box.

Meter Cal Calculated	
0.00	

9. To save value, press Confirm softkey - the new Meter Cal is automatically saved.



10. Rotate 3-way valve handle 90° counter-clockwise to standard operating position.
11. Replace Pump-pak cover.

Appendix E – Fine Tuning Speed/Distance Calibration

Accurately measure a distance of 1000 feet (300 meters).
Clearly mark the start and end points with flags or other visible marker.

PROCEDURE

1. Place the system into HOLD by pressing the HOLD softkey.
2. Navigate to the Totals Screen. Reset a distance counter by pressing “RESET” until the display returns to 0.
Make sure pump is off, then turn on the sections.
3. You are now ready to drive the measured course. Pick a location on the vehicle to use as a marker for starting and stopping the distance counting function (door handle, mirror, step, etc.). You should begin driving the course well ahead of the starting flag and drive past the ending flag, using the Run/Hold switch to start and stop the counting function. It is not recommended to start from a dead stop at the starting flag and stop at the ending flag.
4. Place the system in RUN when the marker on the vehicle passes the starting flag to activate the distance counting function. The console display numbers will increase, adding to the distance total as you drive.
5. Drive the pre-measured course and place the system in HOLD when the marker on the vehicle passes the ending flag, to stop the distance counting function.
6. Check the accumulated distance on the counter. If the number displayed is within 1% than the measured distance driven, the calibration is within tolerance and the test is done.
7. If the number is more than 1% different, adjust the Speed Cal value in Configuration/Tab A screen.
If the counter number is larger than the driven distance, calculate the percentage of difference and **reduce** the Speed Cal by the same percent.
If the counter number is smaller than the driven distance, calculate the percentage of difference and **increase** the Speed Cal by the same percent.
8. The system is now calibrated. To verify calibration, repeat the procedure a second time.

Appendix D – Replacement Parts

In The Cab On the Tractor Parts

19671	3RIVE 3D™ Dual Plus ISOmod Manual (Net Price only)	18895	Ampseal (John Deere) Tap Cable
19020	3RIVE 3D™ Dual Plus ISOmod module	18896	Delphi MP630 (Great Plains/Dickey John) Tap Cable
13181	SafeGuard Console Mount Kit	18897	Delphi GT280 (Case) Tap Cable
19360	3RIVE 3D™ SafeGuard Console	18921	IBIC Breakaway Cable
18982	3RIVE 3D™ SafeGuard Power Cable	18944	Deutsch DTM Tap Cable (in-cab) Kit with power cable
18526	6Pin 5' M/P to JWPF Adapter Cable	18945	Deutsch DT Tap Cable (in-cab) Kit with power cable
19361	3RIVE 3D™ SafeGuard Manual (Net price only)	18950	Deutsch DT Tap Cable (in-cab) Kit with power adapter
18894	M/P 150 (Generic) Tap Cable		

On The Planter Parts

19226	15' 29Pin 3RIVE 3D™ Dual Junction Harness	19108	Air Regulator Mount Bracket
19020	3RIVE 3D™ ISOMOD Module	19129	100 PSI Pressure Sensor
19298	3RIVE 3D™ ISOMOD Junction Harness	19131	Air Pressure Regulator
01840	SafeGuard Implement Switch Kit	19163	60 PSI Pressure Gauge
18531	Implement Switch Module	19286	2' Pressure Sensor Adapter cable
18541	Whisker Switch w/Bracket & Mag Mount	19429	UBolt, 3/8" x 7" x 7" x 7"
19162	1/2" x 50 Mesh Water Strainer (Red)	12522	1/2" MPT x 1/2" Barb Tee PP Black
19238	1/2" PolyPro Water/Chem Tank Valve	12526	1/2" FPT x 1/2" FPT Tee PP Black
19144	3/4" PolyPro Water Rinse Valve	12527	1/2" MPT x 1/2" MPT Nipple Black
19234	3/4" 50 Mesh Chem Strainer	13947	1/2" MPT x 1/2" Barb PP Black

PumpPak Related Parts

18104	10Amp PWM EMD Module	19153	3/8" Braided Vinyl Hose
19110	1/4" 3Way Solenoid Valve	19576	DZUS 1/4 Turn Fastener Stud
19285	PumpPak Channel 1 Branch Cable	19577	DZUS 1/4 Turn Receptacle
19287	PumpPak Channel 2 Branch Cable	19442	1/2" Quick Coupler Panel Mount
19356	PumpPak Power Branch Cable	19443	3/4" Quick Coupler Insert
19359	Gear Motor Interface Cable	19373	Tubing 1/4" ID x 3/8" OD Blue
22034	Crouzet Chemical Gear Motor	19374	Tubing 1/4" ID x 3/8" OD White
22035	Watson Marlow Pumphead	19375	Tubing 1/4" ID x 3/8" OD Black
19363	Remco Water Pump	19477	Tubing 1/4" ID x 3/8" OD Green
19425	Flowmeter Sensor Cable 6"	19548	3/8" Stem x 1/2" Barb Black
22032	FM250 P Flowmeter	19596	1/4" MPT x 3/8" PTC Black
19371	1/2" Side Load Banjo Valve	19597	1/4" MPT x 3/8" PTC Swivel 90° Black
19383	3.2 Metering Tube	19148	3/8" Stem x 3/8" PTC Black
19384	2.4 Metering Tube	19202	3/8" Stem x 3/8" Barb Black
19385	1.6 Metering Tube	19251	1/4" FPT x 3/8" PTC Black
19611	Single Relay Control Module	19557	1/2" x 1/2" x 1/2" Barb Tee Black
18837	Air Compressor w/Adapter	19560	1/2" MPT x 3/8" PTC Black
19126	Air Compressor Air Filter 1/4"	19561	3/8" PTC x 3/8" MPT Tee Black
19164	1/4" S.S Street Elbow	19170	Big Air 30 Amp Power Fuse Holder Kit
19151	1/2" Braided Vinyl Hose	19295	Big Air 30' 2pin M/P 480 Power Cable

Chemical & Water Tank Related Parts

19144	3/4" FP 4Bolt PolyPro Valve	19560	1/2" MPT x 3/8" PTC Black
19162	1/2" x 50 Mesh Red Strainer	19233	3/4" MPT x 3/4" Barb 90° PP Black
19234	3/4" 50 Mesh Micro Strainer	19594	3/4" Rubber Spiral Hose
19238	1/2" FP Union PolyPro Valve	10509	3/4" MPT x 1/2" Barb PP Black
12527	1/2" MPT x 1/2" MPT Nipple Black	19148	3/8" Stem x 3/8" PTC 90° Black
19165	3/4" MPT x 3/4" MPT Nipple Black	19441	3/4" MPT x 1/2" FPT Bushing
19185	3/4" FPT x 3/4" FPT Tee PP Black	12526	1/2" FPT x 1/2" PFT Tee PP Black
19186	3/4" MPT x 1/2" MPT Nipple Black	12527	1/2" MPT x 1/2" MPT Nipple Black
19242	3/4" MPT x 3/4" Barb PP Black	13947	1/2" MPT x 1/2" Barb PP Black

Section Tower Related Parts

18500	6pin 20' JWPF Extension Cable	19249	Air Disc 3 #40
18510	SafeGuard Sensor UClip, S.S	19250	Nipple, 11/16" x 1/4" PP
18514	SafeGuard Sensor Retainer Clip	19375	Tubing 1/4" ID x 3/8" OD Black
18627	Plug Fitting 3/8" John Guest 90 ⁰	19409	3/8" Stem x 1/4" PTC
18687	Pink Cartridge (Net price only)	19410	1/4" Tubing
18822	3RIVE 3D™Foam Blockage Sensor	19512	4Row Splitter Cable
19083	Mixing Tee Fitting	19513	6Row Splitter Cable
19119	Mixing Tee 1" Gasket	19541	Coiling Bracket
19120	Mixing Tee Clamp	19542	1/4" Zip Valve
19148	3/8" Stem x 3/8" PTC 90 ⁰ Black	19544	Row Valve Bracket
19151	1/2" Braided Vinyl Hose	19545	Section Tower Bracket
19153	3/8" Braided Vinyl Hose	19546	3pin W/P to 4pin M12 cable
19192	Foam Manifold Assembly	19599	M12 Dust Cover
19202	3/8" Stem x 3/8" Barb Black	19547	1/4" Stem x 1/4" PTC 90 ⁰ Black
19219	UBolt, 3/8" x 7" x 9"	19548	3/8" Stem x 1/2" Barb Black
19194	Liquid Core Disc	19549	1/4" FPT x 1/4" PTC
19244	Liquid Disc D1	19550	1/4" PTC Straight Quick Cap Black
19246	Liquid Disc D2	19551	1/4" FPT Quick Body Black
19247	Liquid Disc D4	19552	EPDM Rubber Seal
19195	Air Disc 1 #30	19553	1/4" MPT x 3/8" Stem Black
19248	Air Disc 2 #35		

InFurrow Delivery Related Parts

19121	S.S Foam Tube Straight
19122	S.S Foam Tube Bent
19497	3/*8" PTC x 1/4" PTC Union Black

Proudly manufactured in the U.S.A. by:



MICRO-TRAK[®]
SYSTEMS, INC.

111 East LeRay Ave., Box 99, Eagle Lake, MN 560240099

Toll Free: 800-328-9613

507-257-3600 • Fax 507-257-3001

www.microtrak.com • email: trakmail@microtrak.com

Copyright © 2017 • Micro-Trak[®] Systems, Inc.

REV. A

P/N 19671 • 042417